

O U T D O O R

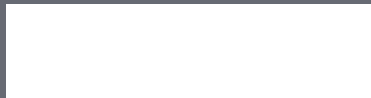

2 0 1 9

rocersa®

rocersa®





2022

UPTA



- OUTDOOR 20
- DDS
- PORCELAIN TILES

<b>● MADERAS / wood</b>		<b>75</b>
● EVERGLOW		77
● FLOW		85
● ICON		93
● OLD STATION		99
● VENICE		105

<b>A</b>		
●● ARUBA		183
●● ATMOSPHERE		111
●● AXIS		191

<b>B</b>		
●● BELFORT		119
●● BLACKSHEEP		199
●● BLUENORTE		205
●● BRUGES		211

<b>C</b>		
●● CHRONO		219
●● CITADEL		227
●● CONTRACT		125

<b>D</b>		
●● DOVER		235

<b>● CEMENTOS / CEMENTS</b>		<b>109</b>
●● ATMOSPHERE		111
●● BELFORT		119
●● CONTRACT		125
●● ETERNAL STONE		133
●● MAKE UP		145
●● MUSTANG		167
●● SYNERGY		175

<b>E</b>		
●● ETERNAL STONE		133
●● EVERGLOW		77

<b>F</b>		
●● FLOW		85

<b>I</b>		
●● ICON		93

<b>L</b>		
●● LIVERMORE		243

<b>● PIEDRAS / STONE</b>		<b>181</b>
●●● ARUBA		183
●●● AXIS		191
●● BLACKSHEEP		199
●● BLUENORTE		205
●● BRUGES		211
●● CHRONO		219
●● CITADEL		227
●● DOVER		235
●● LIVERMORE		243
●● MATERIA		255
●● MOON		263

<b>M</b>		
●● MAKE UP		145
●● MATERIA		255
●● MOON		263
●● MUSTANG		167

<b>O</b>		
●● OLD STATION		99

<b>S</b>		
●● SYNERGY		175

<b>V</b>		
●● VENICE		105

<b>20X20 RC</b>		
●● BRUGES		211
●● ETERNAL STONE		133
●● MAKE UP		145

<b>29,5X120 RC</b>		
●● EVERGLOW		77
●● FLOW		85
●● ICON		93
●● OLD STATION		99

<b>50X100 RC</b>		
●●● ARUBA		183

<b>60X60 RC</b>		
●●● ARUBA		183
●● ATMOSPHERE		111
●● AXIS		191
●● BELFORT		119
●● BLUENORTE		205
●● CHRONO		219
●● DOVER		235
●● ETERNAL STONE		133
●● LIVERMORE		243
●● MAKE UP		145
●● MATERIA		255
●● MOON		263
●● MUSTANG		167
●● SYNERGY		175
●● VENICE		105

<b>61X61</b>		
●● ATMOSPHERE		111
●● AXIS		191
●● BELFORT		119
●● BLUENORTE		205
●● CHRONO		219
●● DOVER		235
●● LIVERMORE		243
●● MATERIA		255
●● MUSTANG		167
●● SYNERGY		175
●● VENICE		105

<b>60X120 RC</b>		
●● ATMOSPHERE		111
●● AXIS		191
●● BLACKSHEEP		275
●● CHRONO		219
●● CITADEL		147
●● CONTRACT		245
●● DOVER		235
●● LIVERMORE		43
●● MAKE UP		257

<b>75X75 RC</b>		
●● BELFORT		119
●● BLACKSHEEP		275
●● BLUENORTE		205
●● CITADEL		147
●● DOVER		235
●● MATERIA		255
●● MUSTANG		167

<b>100X100 RC</b>		
●●● ARUBA		183
●● ETERNAL STONE		133
●● MAKE UP		145
●● MOON		263



## USO DEL CATÁLOGO USE OF THE CATALOG

La reproducción de los colores es aproximada debido a los sistemas de impresión.

Los códigos de precios y las referencias deben verificarse ya que pueden haber errores tipográficos.

El fabricante se reserva el derecho de modificar las características del packing según las condiciones del pedido.













*Given the printing systems in use, the colours reproduced herein are roughly equivalent to actual ones.*

*Price code and product codes should be checked since there be typographical errors.*

*The manufacturer reserves the right to modify the characteristics as per the terms and conditions of the order.*

### \*Simbología

\*Symbology

-  Revestimiento  
Wall tiles
-  Pasta blanca  
White body color
-  Pavimento  
Floor tiles
-  Pavimento coordinado  
Co-ordinated floor tile
-  Mate  
Matt
-  Brillo  
Gloss
-  Porcelánico  
Porcelain tile
-  Antihielo  
Frost resistance
-  Masa coloreada  
Color body
-  Rectificado  
Rectified
-  Antideslizante  
Anti slip
-  Destonificado  
Shading variations

**R9** **R10** **R11** Antideslizante R9  
Anti slip R9

**R10** **R11** **R12** Antideslizante R10  
Anti slip R10

**R11** **R12** **R13** Antideslizante R11  
Anti slip R11

**CTE 1** **CTE 2** **CTE 3** **R11 A+B+C** CTE  
CTE

**V1** **V3** Uniforme  
Uniform Moderada  
Moderated

**V2** **V4** Ligera  
Slight Considerable  
Substantial



Pie de foto  
Caption

Imagen de la serie  
Environment of the serie



Simbología\*  
Symbology\*

Imagen de pieza  
Tile image

Serie y colores  
Serie and colors

# EVER GLOW

Serie  
Serie

Colores  
Colors

Formatos  
Sizes

Propiedades  
Properties

Nº de página  
Page number

**OUT200R** Espesor 20mm  
20mm width

**DDS** Tecnología Dry Digital system  
Dry Digital System Technology

Formatos  
Sizes

RO01W31738	CHARISMA WHITE RC	19,4x120cm RC	B 310
------------	-------------------	---------------	-------

ID Código  
ID Code

Descripción  
Description

Formato (cm)  
Size (cm)

ID Precio  
Price ID



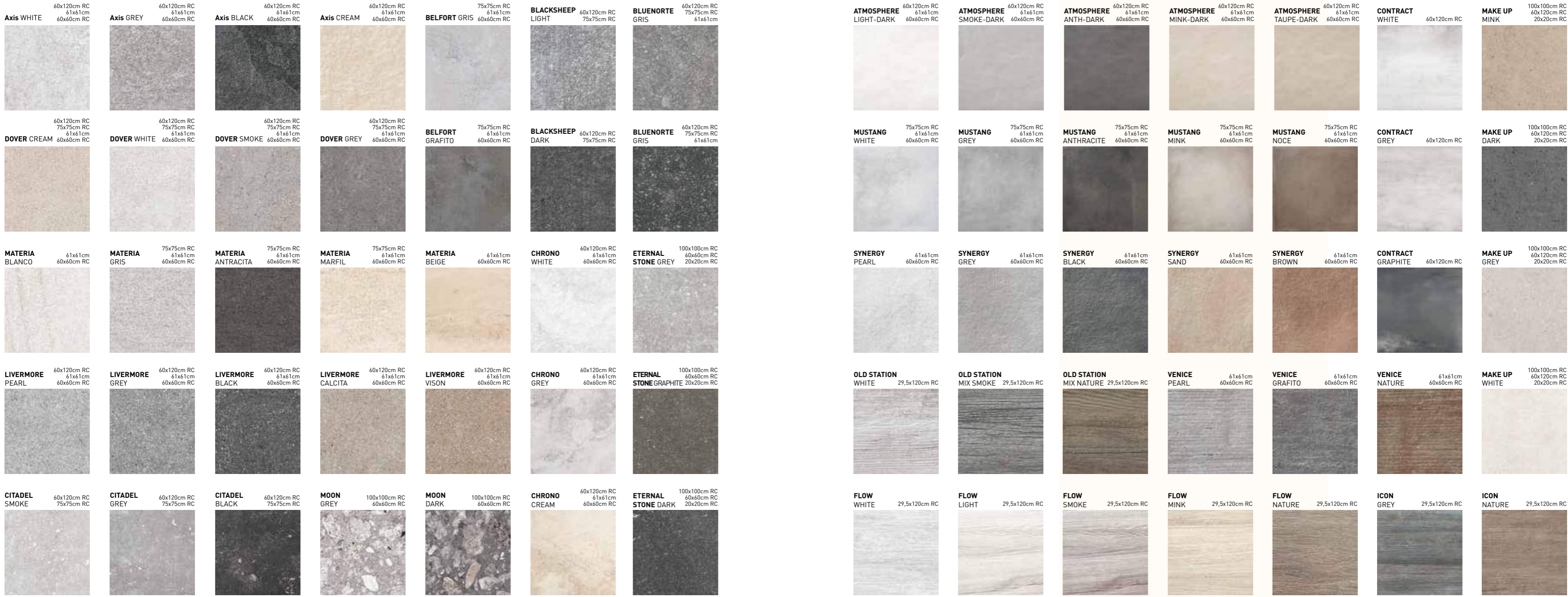

# OUTDOOR

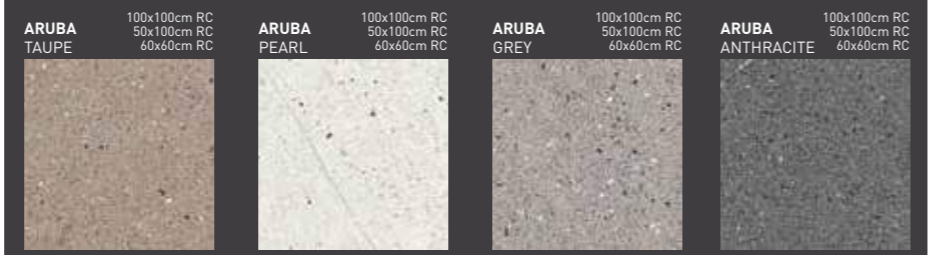

Dry Digital System **DDS**

# 20 MM



## 1. CARACTERÍSTICAS

Outdoor 20 es un gres porcelánico de 20mm de espesor especialmente ideado para su uso en exterior. Su elevada resistencia a la carga de rotura y las tensiones, así como sus extraordinarias prestaciones antideslizantes, hacen de Outdoor 20 el gres ideal para ambientes externos, tanto públicos como privados.

### DURABILIDAD ILIMITADA

- Anti-hielo e ignífugo.
- Alta resistencia a agentes químicos y atmosféricos.
- No le afectan ni el musgo ni los insectos.
- Fácil limpieza y mantenimiento.

## 1. CHARACTERISTICS

Outdoor 20 is a 20mm thick porcelain tile especially designed for outdoor use. Its high resistance to breaking load and stress, as well as its extraordinary slip-resistant features, make Outdoor an ideal tile for outdoor areas, both public and private.

### UNLIMITED DURABILITY

- Anti-icing and fireproof.
- High resistance to chemical and atmospheric agents.
- Not affected by moss or insects.
- Easy to maintain and clean.

## 1. CARACTÉRISTIQUES

Outdoor 20 est un grès cérame de 20 mm d'épaisseur spécialement conçu pour son utilisation à l'extérieur. Il a été spécialement conçu pour une utilisation à l'extérieur. Sa haute résistance à la charge de rupture et de stress ainsi que ses performances anti-glissement extraordinaires, nous permettent dire que le grès cérame Outdoor 20 est idéal pour les environnements extérieurs, soient-ils publics ou privés.

### DURABILITÉ ILLIMITÉE

- Anti-glace et anti-feu.
- Haute résistance aux agents chimiques et atmosphériques.
- Il ne se voit pas affecté par la mousse ni par les insectes.
- Nettoyage et entretien faciles.

## 1. EIGENSCHAFTEN

Outdoor 20 ist eine Porzellankeramik mit einer Höhe von 20mm, die spezifisch für ihre Benutzung in Außenbereichen konzipiert worden ist. Ihre hohe Druckfestigkeit und Resistenz gegen Spannungen, als auch ihre außerordentliche Rutschfestigkeit, machen aus Outdoor 20 die ideale Keramikfliese für öffentliche und private Außenbereiche.

### UNBEGRENZTE LEBENSDAUER

- Frostsicher und feuerbeständig.
- Große Widerstandsfähigkeit gegen Chemikalien und wetterbedingte Einwirkungen.
- Beständig gegen Moos und Insekten.
- Leichter Unterhalt und Reinigung.







## 2. VENTAJAS

Outdoor 20 ofrece numerosas ventajas respecto a otros materiales naturales que se han utilizado tradicionalmente en exterior.

1. No tiene absorción de agua.
2. Resiste a los ataques químicos.
3. Resiste a la sal que se echa en el suelo para el hielo.
4. No le afectan ni el moho ni el musgo.
5. Viene perfectamente calibrado y con un espesor uniforme.
6. Se limpia fácilmente.
7. Se mantiene inalterable en el tiempo, tanto sus colores como sus características técnicas.
8. Permite un mejor desarrollo estético.
9. Permite la continuidad del mismo pavimento tanto en el interior como en el exterior.
10. No absorbe y se limpia fácilmente.
11. Anti-hielo.
12. Ignífugo.
13. Tráfico ligero.
14. Pieza complementaria.
15. Fácil manipulación

## 2. ADVANTAGES

Outdoor 20 offers many advantages compared to other natural materials that have traditionally been used outdoors.

1. Does not absorb water.
2. Resistant to chemical attacks.
3. Resistant to the salt used for melting ice.
4. Not affected by mould or moss.
5. It comes perfectly calibrated and its thickness is uniform.
6. Easy to clean.
7. Remains unaltered over time, both in colour and technical characteristics.
8. Allows for a better aesthetic development.
9. Allows the continuity of the same flooring both inside and outside.
10. Easy to clean and non-absorbent.
11. Anti-icing
12. Fireproof
13. Light traffic
14. Complementary piece
15. Easy manipulation

## 2. AVANTAGE

Outdoor 20 offre des nombreux avantages par rapport à d'autres matériaux naturels qui ont été utilisés traditionnellement à l'extérieur.

1. Pas d'absorption d'eau.
2. Résistance aux attaques chimiques.
3. Résistance au sel du déglçage.
4. Il ne se voit pas affecté par la moisson.
5. Il est livré avec une parfaite épaisseur uniforme calibrée.
6. Facile à nettoyer.
7. Il reste inaltérable au fil du temps, autant leurs couleurs que leurs caractéristiques techniques.
8. Permet un meilleur développement esthétique.
9. Permet la continuité de la chaussée à l'intérieur et à l'extérieur.
10. Il n'absorbe pas les liquides et se nettoie facilement.
11. Anti-glace
12. Anti-feu
13. Trafic léger
14. Pièce complémentaire
15. Manipulation facile

## 2. VORTEILE

Outdoor 20 bietet zahlreiche Vorteile gegenüber anderen natürlichen Materialien, die traditionell in Außenbereichen benutzt worden sind.

1. Keine Wasseraufnahme.
2. Beständig gegen Chemikalien.
3. Beständig gegen Streusalz.
4. Leidet nicht unter Moos oder Insekten.
5. Sie sind perfekt kalibriert und haben eine einheitliche Höhe.
6. Die Reinigung ist einfach.
7. Sowohl die Farben als auch die technischen Eigenschaften bleiben im Laufe der Zeit unverändert.
8. Ermöglicht eine bessere Ästhetik.
9. Ermöglicht die Weiterführung des gleichen Bodens in Innen- und Außenbereichen.
10. Es nimmt keine Stoffe auf und lässt sich leicht reinigen.
11. Frostsicher
12. Feuerbeständig
13. Leichter Verkehr
14. Zusatzteile
15. Einfache Handhabung

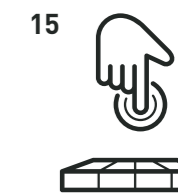
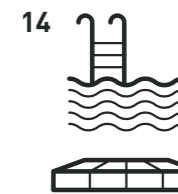
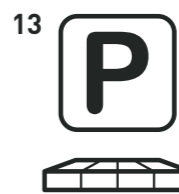
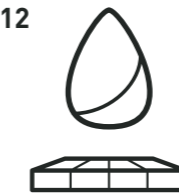
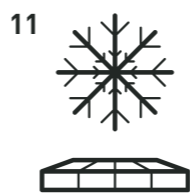
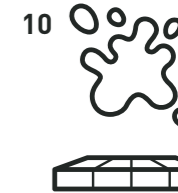
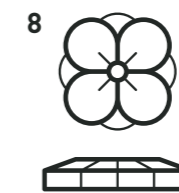
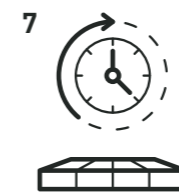
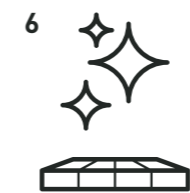
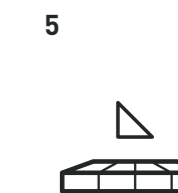
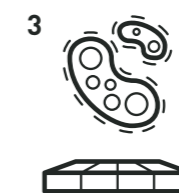
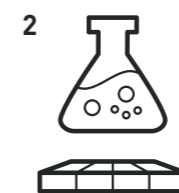
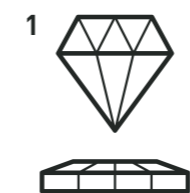





DOVER 20 SMOKE 60x120cm RC

### 3. DÓNDE

Su extraordinaria resistencia, su facilidad de instalación y su sofisticado diseño permiten la colocación de Outdoor 20 en prácticamente cualquier espacio exterior y, por qué no, interior. La imaginación es el límite.

#### ÁMBITO DOMÉSTICO

- Jardines
- Pasadizos
- Patios
- Piscinas
- Terrazas
- Muros
- Escaleras

#### ESPACIOS PÚBLICOS

- Hoteles (zonas comunes, piscinas, terrazas, etc.).
- Balnearios.
- Áreas residenciales.
- Áreas industriales.
- Pavimento urbano.
- Playas (sobre arena).
- Zonas con tráfico rodado leve (sobre baldosas colocadas, sistema tradicional).

### 3. WHERE

Its extraordinary resistance, easy installation and sophisticated design mean that Outdoor 20 can be installed in practically any exterior and, why not, interior space. Imagination is the limit.

#### IN THE HOME

- Gardens
- Courtyards
- Terraces
- Stairs
- Passageways
- Pools
- Walls

#### PUBLIC SPACES

- Hotels (communal areas, pools, terraces, etc.).
- Spas.
- Residential areas.
- Industrial areas.
- Urban paving.
- Beaches (over sand).
- Areas with mild road traffic (over paving stones installed, traditional system).

### 3. OÙ

Sa résistance extraordinaire, facilité de mise en place et son design permettent d'installer Outdoor 20 dans pratiquement n'importe quel espace extérieur et, pourquoi pas, à l'intérieur. L'imagination n'a pas de limites.

#### DOMAINE DOMESTIQUE

- Jardins
- Passages
- Patios
- Piscines
- Terrasses
- Murs
- Escaliers

#### ESPACES PUBLICS

- Hôtels (foyer, piscines, terrasses, etc.).
- Spas.
- Zones piéton.
- Zones industrielles.
- Trottoirs.
- Plages (sur le sable).
- Zones à trafic léger (sur les carrelages mis avec un système traditionnel).

### 3. WO

Ihre außerordentliche Widerstandsfähigkeit, die leichte Legung und ihr durchdachtes Design erlauben die Legung von Outdoor 20 in fast jedem Bereich im Freien oder, wieso nicht, im Inneren. Die Vorstellungskraft ist die einzige Grenze.

#### IM HÄUSLICHEN BEREICH

- Gärten
- Gänge
- Höfe
- Swimmingpools
- Terrassen
- Mauern
- Treppen

#### IM ÖFFENTLICHEN BEREICH

- Hotels.
- Bäder / Spas.
- Wohnanlagen.
- Industrieanlagen.
- Orte mit wenig Verkehr (mit der traditionellen Verlegung).



ALPENA 20 PIEDRA 60x60cm RC



CONTRACT 20 GREY 60x120cm RC - CONTRACT 20 GRAPHITE 60x120cm RC



## 4. COLOCACIÓN

### SISTEMA SOBRE-ELEVADO

Otro de los aspectos revolucionarios de Outdoor 20 es su sistema de colocación sobre soportes portantes o plots. Este ingenioso sistema permite superar todas las limitaciones que ofrecía la colocación externa con métodos tradicionales.

### SISTEMA SOBRE-ELEVADO

- No va ligado a la estructura de la edificación, evitando posibles fisuras y roturas (ventaja importante para las partes expuestas a la luz solar y la intemperie).
- Facilidad de mantenimiento e inspección de las instalaciones que hay debajo, permitiendo utilizar la parte inferior para las canalizaciones de agua, luz, sistemas de riego, etc.
- Mayor insonorización acústica y cámara de aire para el aislamiento térmico.
- Consigue una pavimentación plana y continua, sin tener que crear pendientes para el drenaje, como rejillas o desagües.
- Ideal para zonas con problemas de pesos estructurales, como balcones, gracias a su bajo peso (47Kg/m<sup>2</sup>).
- La abertura entre baldosas (+/- 3mm) facilita el drenaje del agua.
- Garantía contra expansiones ó contracciones de los suelos.
- Evita las filtraciones de agua entre el material y el impermeabilizante.
- Menor coste en colocación: no es necesario personal de alta cualificación.
- Fácil y limpio de colocar, ya que no requiere de colas adhesivas.
- Fácilmente desmontable y reutilizable.
- Se puede intervenir sobre la capa de impermeabilización sin romper el pavimento, reduciendo significativamente tiempos y costes.

## 4. INSTALLATION

### IN THE HOME

Another revolutionary feature of Outdoor 20 is its installation system over bearing supports or plots. This ingenious system allows you to overcome all the limitations of exterior installation using through traditional methods.

### ADVANTAGES

- It is not linked to the building structure, avoiding possible cracking or breaking (important advantage for those parts exposed to sunlight and outdoor conditions).
- Easy maintenance and inspection of the facilities underneath, allowing the bottom part to be used for water pipes, electricity, irrigation systems, etc.
- Increased soundproofing and air chamber for thermal insulation.
- Achieves flat and continuous paving, without having to create slopes for drainage, such as grating or drains.
- Due to its low weight (47kg/m<sup>2</sup>), it is ideal for areas with structural weight problems, such as balconies.
- The spacing between tiles (+/- 3mm) facilitates water drainage.
- Guarantee against floor expansions or contractions.
- Prevents water leakage between the material and waterproof agent.
- Lower installation cost: no need for highly qualified staff.
- Easy and clean to install, no adhesive glue is necessary.
- Easily demountable and reusable.
- It is possible to work over the waterproofing layer without breaking the paving, considerably reducing time and costs.

## 4. MIS EN PLACE

### SYSTÈME SURÉLEVÉ

Parmi les aspects révolutionnaires de Outdoor 20 se trouve sa mise en place sur des supports ou plots. Ce système ingénieux permet de surmonter toutes les limitations offertes par les méthodes de mise en place traditionnelle à l'extérieur.

### AVANTAGES

- Il n'est pas lié à la structure du bâtiment, ce qui évite la possible fissuration et la rupture (un avantage important pour les zones exposées au soleil et aux intempéries).
- Facilité d'entretien et d'inspection des installations qui se trouvent au-dessous. Ce qui vous permet d'utiliser le fond pour les tuyaux d'eau, d'électricité, les systèmes d'irrigation, etc.
- Plus grand isolement acoustique et chambre à air pour l'isolement thermique.
- Vous pouvez construire un trottoir plat en continu sans avoir à créer de pentes pour le drainage comme les grilles ou les égouts.
- Idéal pour les zones ayant des problèmes de poids structurels, tels que les balcons, en raison du faible poids (47 kg/m<sup>2</sup>).
- L'ouverture entre les carreaux (+ / - 3 mm) facilite le drainage de l'eau.
- Garantie contre les expansions et contractions des pièces.
- Évite les filtrations d'eau entre les pièces et la couche d'étanchéité.
- Coût bas d'installation: pas besoin de personnel hautement qualifié.
- Facile à installer et propre. Pas besoin d'application de colles.
- Facilement démontable et réutilisable.
- Vous pouvez travailler sur la couche d'étanchéité sans casser la chaussée, ce qui réduit considérablement le temps des travaux et les coûts.

## 4. VERLEGUNG

### SCHWIMMENDE VERLEGUNG

Eine andere revolutionäre Eigenschaft von Outdoor 20 ist das Verlegungssystem auf Trägern. Dieses durchdachte System, ermöglicht alle Hindernisse der traditionellen Legung in Außenbereichen zu überwinden.

### VORTEILE

- Es weicht möglichen Rissen oder Brüchen aus, da es ist nicht an die Struktur des Gebäudes gebunden ist (ein wichtiger Vorteil für die Teile die dem Sonnenlicht und schlechtem Wetter ausgesetzt sind).
- Es ermöglicht eine leichte Wartung und Untersuchung der Anlagen die sich unter den Fliesen befinden. Man kann den Raum unter den Fliesen nutzen um Wasser, Strom – und Bewässerungsanlage unterzubringen.
- Es entsteht eine bessere Schallsolierung und eine Luftkammer für Wärmeisolierung.
- Es entsteht ein flacher und gleichmäßiger Boden ohne Steigungen, Gitter oder Abläufe für die Entwässerung.
- Durch das niedrige Gewicht (47Kg/m<sup>2</sup>) ist es ideal für Orte mit struktureller Problematik wie Balkone.
- Der Raum zwischen den Fliesen (+/- 3mm) erleichtert Entwässerung.
- Eine Garantie gegen Dehnungen und Kontraktionen des Bodens.
- Verhindert das Durchsickern von Wasser zwischen dem Material und der Abdichtung.
- Geringere Verlegungskosten, da kein hoch qualifiziertes Personal benötigt wird.
- Leicht und sauber zu verlegen, da keine Klebstoffe benötigt werden.
- Wiederabbau- und Verwendung sind einfach.
- Man kommt an die Abdichtung ohne die Fliesen zu beschädigen und reduziert damit Zeitaufwand und Kosten.

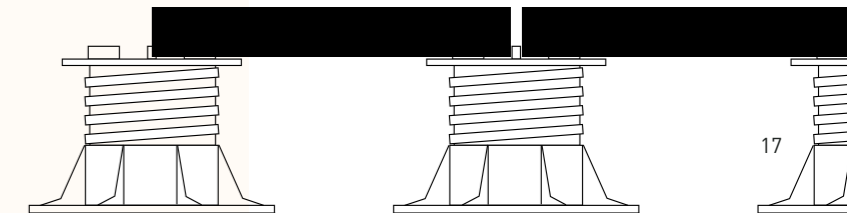





CONTRACT 20 WHITE 60x120cm RC

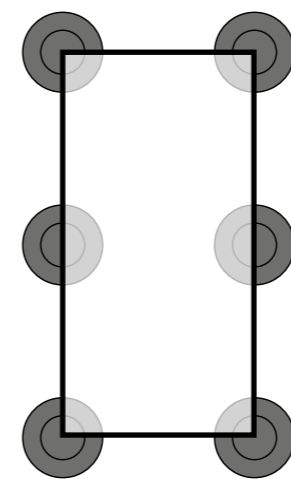

50x100 cm RC ± 4 PLOTS / m<sup>2</sup>

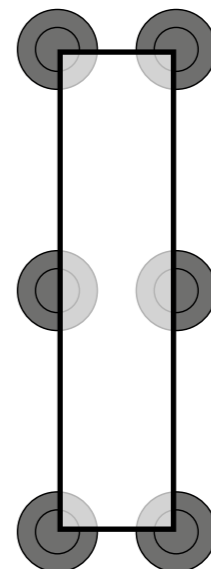

29,5x120 cm RC ± 6,2 PLOTS / m<sup>2</sup>

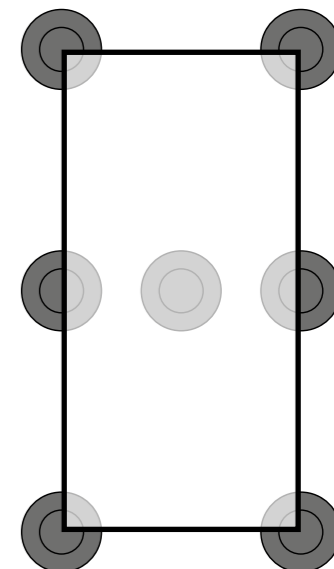

60x120 cm RC ± 4,2 PLOTS / m<sup>2</sup>

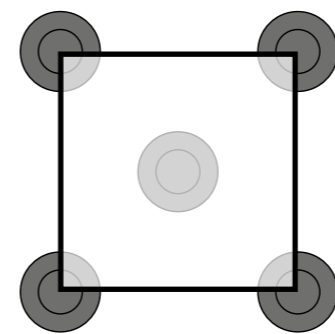

61x61 / 60x60 cm RC ± 3,2 PLOTS / m<sup>2</sup>

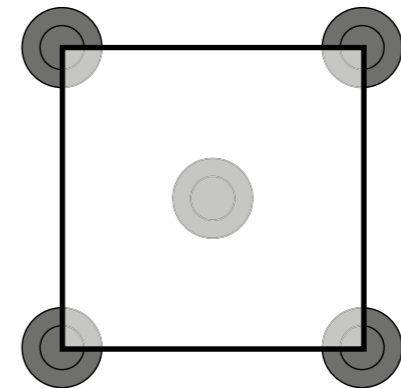

75x75 cm RC ± 3,2 PLOTS / m<sup>2</sup>

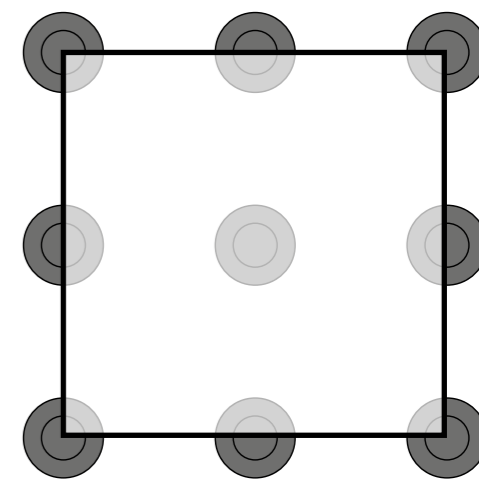

100x100 cm RC ± 4 PLOTS / m<sup>2</sup>

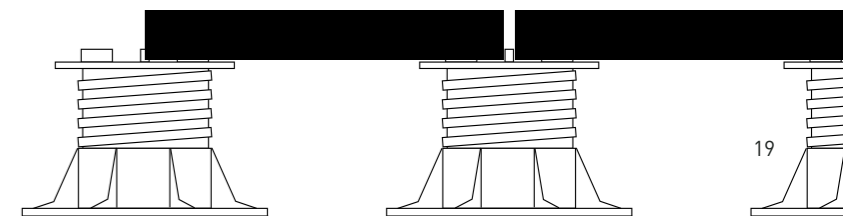





AUTO-NIVELANTE  
SELF-LEVELLING  
SELBSTNIVELLIERENDE  
AUTONIVELANT

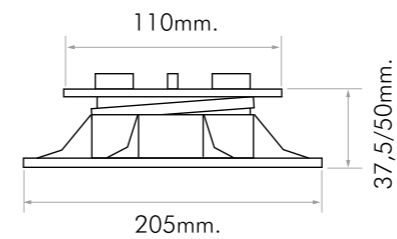
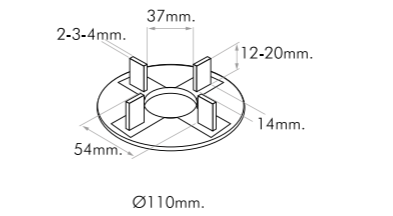

H37,5-50 37,5-50 mm C 85

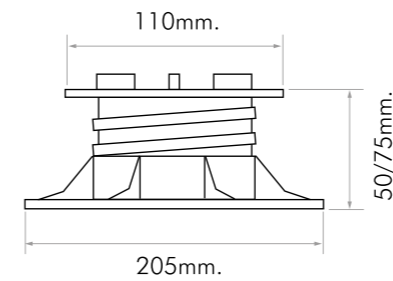

H50-75 50-75 mm CP094

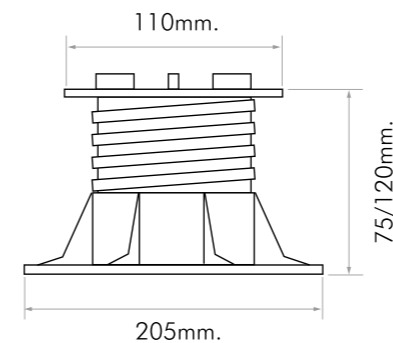

H75-120 75-120 mm C 103

REGULABLE  
REGULABLE  
REGULIERBAR  
REGULABLE

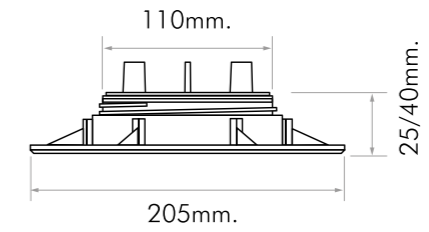
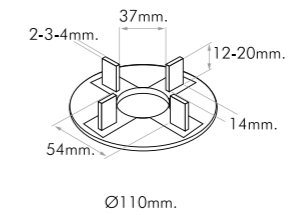

H25-40 25-40 mm CP049

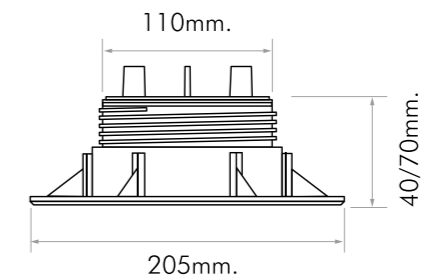

H40-70 40-70 mm CP050

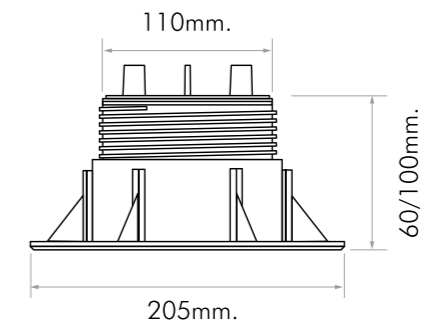

H60-100 60-100 mm CP062

FIJO  
FIXED  
FESTER  
FIXÉ

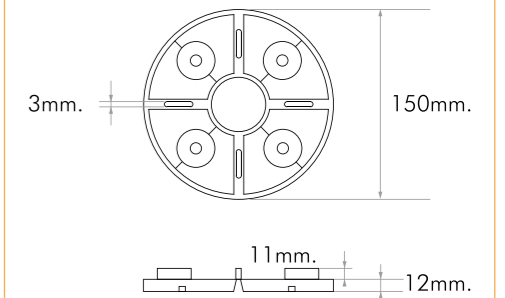
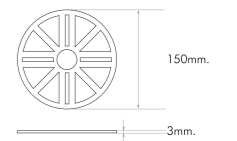

H12 12 mm CP005

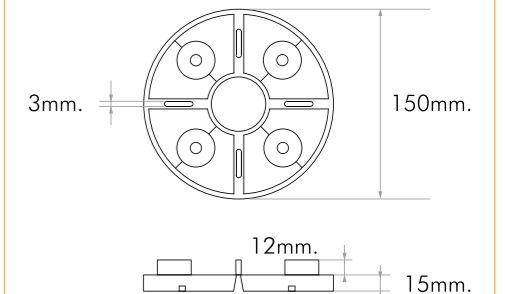

H15 15 mm CP006

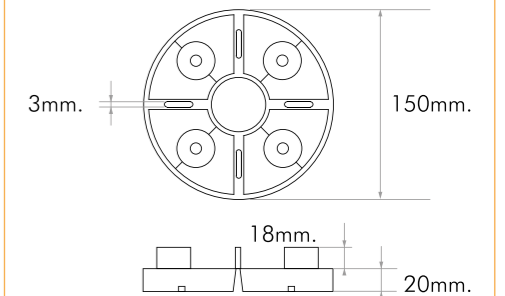

H20 20 mm CP009







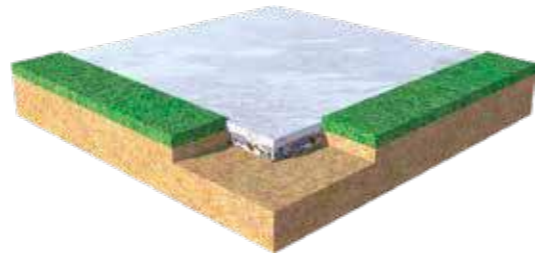

## SOBRE CÉSPED ON GRASS SUR L'HERBE AUF GRAS

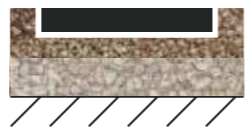

## SOBRE GRAVILLA ON GRAVEL SUR LE GRAVIER AUF KIES



## SOBRE ARENA ON SAND SUR SABLE AUF SAND

### 4. COLOCACIÓN

OTROS SISTEMAS: EN SECO

Outdoor 20 puede colocarse con facilidad sobre gravilla (5-6cm de gravilla de una granulometría de 4-8mm), hierba (gravilla sobre la hierba) o arena.

VENTAJAS

- No requiere de colas.
- Colocación rápida, ecológica y de alto nivel estético.
- Inmediatamente transitable, y fácilmente removible (evitando problemas legales de colocación).

### 4. INSTALLATION

OTHER SYSTEMS: DRY

Outdoor 20 can be easily installed on gravel (5-6cm of gravel with grain size of 4-8mm), grass (gravel on grass) or sand.

ADVANTAGES

- No glue required.
- Quick to install, ecological and highly aesthetic.
- Immediately passable and quickly removed (avoiding legal installation problems).

### 4. MIS EN PLACE

AUTRES SYSTÈMES: EN SEC

Outdoor 20 peut être mis en place facilement sur le gravier (5 à 6 cm de gravier avec une taille de grains de 4 à 8 mm), de l'herbe (gravier sur l'herbe) ou du sable.

DOMAINE DOMESTIQUE

- Il ne nécessite pas de colles.
- Mis en place rapide, écologique et de haut niveau esthétique.
- Immédiatement utilisable, et facile à enlever (en évitant les problèmes juridiques de mis en place).

### 4. VERLEGUNG

ANDERE SYSTEME: TROCKENVERLEGUNG

Outdoor 20 kann kinderleicht auf Kies (5-6cm hoch angelegter Kies mit einer Korngröße von 4-8mm), Gras (Kies auf dem Gras) oder Sand verlegt werden.

VORTEILE

- Es werden keine Klebstoffe benötigt.
- Schnelle und umweltfreundliche Verlegung, mit hohem ästhetischem Anspruch.
- Sofort begehbar und leicht zu entfernen (was rechtliche Hindernisse bei der Verlegung vermeidet).







#### 4. COLOCACIÓN

##### OTROS SISTEMAS: TRADICIONAL

Técnica adhesiva para pavimentación con tránsito de vehículos, lugares comerciales e industriales, rampas de acceso a garajes, etc.

##### VENTAJAS

- Soporta las tensiones de alto tránsito.
- No absorbe manchas; se limpia fácilmente, incluso con una manguera a presión.

#### 4. INSTALLATION

##### OTHER SYSTEMS: TRADITIONAL

Adhesive method for paving with vehicular traffic, commercial and industrial sites, garage access ramps, etc.

##### ADVANTAGES

- Withstands high traffic stress.
- Does not absorb stains; easy to clean, even with a pressure hose.

#### 4. MIS EN PLACE

##### AUTRES SYSTÈMES: TRADITIONNELLES

Technique de mis en place avec de la colle pour le chaussées, zones commerciales et industrielles, rampes d'accès aux garages, etc.

##### DOMAINE DOMESTIQUE

- Il supporte les efforts produits par un trafic élevé.
- Il n'absorbe pas les liquides, nettoyage facile même avec une lance à pression.

#### 4. VERLEGUNG

##### ANDERE SYSTEME: TRADITIONELLE VERLEGUNG

Mit klebendem Verfahren für den Verkehr von Fahrzeugen, in Einkaufs- und Industriezentren oder für Garageneinfahrten.

##### VORTEILE

- Hält die Belastung von hohem Verkehr aus.
- Saugt keine Flecken auf und ist leicht zu reinigen, sogar mit Hochdruckreiniger.





## 4. PIEZA COMPLEMENTARIA

4. COMPLIMENTARY PIECE

4. PIÈCE COMPLÉMENTAIRE

4. ZUSATZTEILE



1. CARACTERÍSTICAS.
2. VENTAJAS.
3. DÓNDE.
4. PIEZA COMPLEMENTARIA.
5. PISCINAS.
6. MODULAR.



1. CHARACTERISTICS.
2. ADVANTAGES.
3. WHERE.
4. COMPLIMENTARY PIECE.
5. SWIMMING POOLS.
6. MODULAR.



1. CARACTÉRISTIQUES.
2. AVANTAGES.
3. OÙ.
4. PIÈCE COMPLÉMENTAIRE.
5. PISCINES.
6. MODULAR.



1. EIGENSCHAFTEN.
2. VORTEILE.
3. WO.
4. ZUSATZTEILE.
5. SCHWIMMBÄDER.
6. MODULAR.



ING

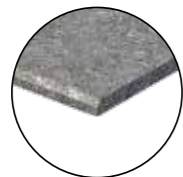

NAT



RE

	Formato / Size [A x L]	Precio Price	Packing [Caja/Box]	
			Ud.	Kg.*
<b>RODAPIÉ RE</b> <b>RISER</b> SOCKEL (ABGERUNDET) PLINTHE ARRONDIE	8x100 cm RC	C137	2	4,200
	8x120 cm RC	C165	2	4,600
	8x20 cm RC	C094	2	2,890
	8x60 cm RC	C094	5	2,200
	8x61 cm	C094	5	2,300
	8x75 cm RC	C138	2	3,296
<b>PELDAÑO ING</b> <b>STAIR TREAD RECTIFIED BORDER</b> STUFE (BULZ AUF GEHRUNG) MARCHE EN ONGLET	20x120 cm RC	C1037	1	17,000
	29,5x120 cm RC	C1037	2	22,000
	30x100 cm RC	*	*	*
	30x60 cm RC	CP358	3	8,800
	30x61 cm	C358	2	8,880
	30x75 cm RC	*	2	7,113
	60x120 cm RC	C1037	1	35,000
	60x60 cm RC	C433	1	17,550
	61x61 cm	C433	2	17,750
75x75 cm RC	C700	1	26,850	
<b>PELDAÑO RE</b> <b>STAIR TREAD BULLNOSE BORDER</b> STUFE (ABGERUNDET) MARCHE ARRONDIE	20x120 cm RC	C1037	1	17,000
	29,5x120 cm RC	C477	1	17,000
	30x100 cm RC	*	*	*
	30x60 cm RC	C165	2	35,000
	30x75 cm RC	*	2	*
	60x120 cm RC	C452	1	35,000
	60x60 cm RC	C189	1	17,550
	61x61 cm RC	C189	1	17,750
	75x75 cm RC	C264	1	26,850
<b>PELDAÑO ÁNGULO RE</b> <b>STAIR TREAD ANGLE BULLNOSE BORDER</b> ECK-STUFE (ABGERUNDET) MARCHE D'ANGLE ARRONDIE	100x100 cm RC	*	*	*
	29,5x120 cm RC	*	2	10,520
	30x30 cm RC	*	1	*
	30x60 cm RC	*	1	8,800
	60x120 cm RC	C477	1	31,194
	60x60 cm RC	C321	1	18,050
	61x61 cm	C272	1	*
	75x75 cm RC	C433	4	28,373

\*Consultar / Check / Nous consulter / Prüfen

\*\* Izquierda y derecha / Left and right / Droite et gauche / Links und rechts

\*\*\*Precio por 2 unidades / Price for 2 units / Prix pour les 2 pièces / Preis pro 2 Stück

Formato / Size [A x L]	Precio Price	Packing [Caja/Box]	
		Ud.	Kg.*

<b>BORDE NAT</b> <b>STEP WIN</b> BORDE NAT BORD NAT	20x100 cm RC	*	*	*	*
	20x120 cm RC	C333	1	17,000	
	20x20 cm RC	C153	12	5,130	
	20x60 cm RC	C137	4	1,750	
	20x75 cm RC	C165	1	8,880	
<b>PELDAÑO ÁNGULO ING</b> <b>STAIR TREAD ANGLE RECTIFIED BORDER</b> ECK-STUFE (BULZ AUF GEHRUNG) MARCHE D'ANGLE EN ONGLET	100x100 cm RC	*	*	*	*
	20x120 cm RC	C1416	1	17,000	
	29,5x120 cm RC	*	1	11,125	
	30x30 cm RC	CP321	2	4,510	
	30x60 cm RC	*	2	8,800	
	60x120 cm RC	C1416	1	31,194	
	60x60 cm RC	C716	1	18,050	
	61x61 cm	C716	1	18,250	
75x75 cm RC	C1173	1	28,373		
<b>FOCO</b> <b>SPOTLIGHT</b> BELEUCHTUNG LED PHOTOVOLTAIQUE	100x100 cm RC	*	*	*	*
	60x120 cm RC	C2329	1	35,000	
	60x60 cm RC	C1300	1	18,050	
	61x61 cm	C1300	1	16,300	
	75x75 cm RC	C1416	1	26,850	
<b>BORDE ING (h=15)</b> <b>COPING RECTIFIED BORDER h=5**</b> BORDE (BULZ AUF GEHRUNG) (h=15) REBORD EN ONGLET (h=15)	10x100 cm RC	*	*	*	*
	10x60 cm RC	C358	1	3,150	
	10x75 cm RC	C558	2	3,900	
	20x120 cm RC	*	1	17,000	
	20x20 cm RC	C153	12	5,130	
<b>BORDE ING</b> <b>COPING RECTIFIED BORDER</b> BORDE (BULZ AUF GEHRUNG) BORD EN ONGLET	20x100 cm RC	*	*	*	*
	20x120 cm RC	C880	1	17,000	
	20x20 cm RC	C153	12	5,130	
	20x60 cm RC	C452	1	6,300	
	20x61 cm RC	C360	4	6,400	
	20x75 cm RC	C539	1	7,860	
<b>BORDE RE</b> <b>COPING BULLNOSE BORDER</b> BORDE (ABGERUNDET) BORD ARRONDIE	20x100 cm RC	*	*	*	*
	20x120 cm RC	C254	1	17,000	
	20x60 cm RC	C137	1	6,300	
	20x61 cm	C116	4	6,400	
	20x75 cm RC	C165	1	7,860	
<b>REJILLA</b> <b>POOL GRID</b> GITTER GRILLE DE CANIVEAU	20x100 cm RC	*	*	*	*
	20x120 cm RC	C1107	1	17,000	
	20x60 cm RC	C524	1	5,050	
	20x61 cm	C499	1	5,150	
	20x75 cm RC	C700	1	6,261	
	29,5x120 cm RC	C1107	1	17,000	

\*Consultar / Check / Nous consulter / Prüfen

\*\* Izquierda y derecha / Left and right / Droite et gauche / Links und rechts

\*\*\*Precio por 2 unidades / Price for 2 units / Prix pour les 2 pièces / Preis pro 2 Stück

Formato / Size [A x L]	Precio Price	Packing [Caja/Box]	
		Ud.	Kg.*

<b>BORDE WIN</b> <b>STEP WIN</b> BORDE WIN BORD WIN	20x100 cm RC	*	*	*	*
	20x120 cm RC	C452	1	17,000	
	20x20 cm RC	C230	12	5,130	
	20x60 cm RC	C165	4	8,880	
	20x75 cm RC	C230	1	22,980	
<b>PELDAÑO NAT</b> <b>STEP NAT</b> STUFE NAT MARCHE NAT	29,5x120 cm RC	C477	1	17,000	
	50x100 cm RC	*	*	*	*
	30x60 cm RC	C165	2	8,880	
	37x75 cm RC	*	1	23,040	
	60x120 cm RC	C452	1	35,000	
<b>REJILLA ÁNGULO **</b> <b>POOL GRID CORNER **</b> ECK-GITTER ** GRILLE DE CANIVEAU ANGULAIRE **	20x100 cm RC	*	*	*	*
	20x120 cm RC	C2329	1	17,000	
	20x60 cm RC	C1079	1	4,200	
	20x61 cm	C1037	4	4,300	
	20x75 cm RC	C1340	4	5,247	
<b>BORDE ÁNGULO EXTERIOR ING **</b> <b>COPING EXTERIOR CORNER RECTIFIED EDGE **</b> ECK-BORDE AUSSEN (BULZ AUF GEHRUNG) ** BORD D'ANGLE EXTERIEUR EN ONGLET **	20x100 cm RC	*	*	*	*
	20x120 cm RC	C1416	1	17,000	
	20x20 cm RC	C298	12	5,130	
	20x60 cm RC	C770	4	5,120	
	20x61 cm	C770	4	5,200	
	20x75 cm RC	C1079	2	6,050	
<b>BORDE ÁNGULO EXTERIOR RE **</b> <b>COPING CORNER BULLNOSE EDGE **</b> ECK-BORDE AUSSEN (ABGERUNDET) ** BORD D'ANGLE EXTERIEUR ARRONDIE **	20x100 cm RC	*	*	*	*
	20x120 cm RC	C524	1	17,000	
	20x20 cm RC	C094	12	5,130	
	20x60 cm RC	C263	4	5,120	
	20x61 cm	C244	4	5,200	
	20x75 cm RC	C358	1	6,050	
<b>BORDE ÁNGULO INTERIOR ING **</b> <b>COPING INTERIOR CORNER RECTIFIED EDGE **</b> ECK-BORDE INNEN (BULZ AUF GEHRUNG) ** BORD D'ANGLE INTÉRIEUR EN ONGLET **	20x100 cm RC	*	*	*	*
	20x120 cm RC	C1416	1	17,000	
	20x20 cm RC	C189	12	5,130	
	20x60 cm RC	C770	1	5,120	
	20x61 cm	C770	4	5,200	
<b>BORDE ÁNGULO INTERIOR RE **</b> <b>COPING INTERIOR CORNER BULLNOSE EDGE **</b> ECK-BORDE INNEN (ABGERUNDET) ** BORD D'ANGLE INTÉRIEUR ARRONDIE **	20x100 cm RC	*	*	*	*
	20x120 cm RC	C524	1	17,000	
	20x20 cm RC	C094	12	5,130	
	20x60 cm RC	C263	4	5,120	
	20x61 cm	C244	4	5,200	

\*Consultar / Check / Nous consulter / Prüfen

\*\* Izquierda y derecha / Left and right / Droite et gauche / Links und rechts

\*\*\*Precio por 2 unidades / Price for 2 units / Prix pour les 2 pièces / Preis pro 2 Stück





## PELDAÑO RE

STAIR TREAD BULLNOSE BORDER · STUFE (ABGERUNDET) · MARCHE ARRONDIE

OUTDOOR

1



20x120 cm RC
29,5x120 cm RC
30x100 cm RC
30x60 cm RC
30x75 cm RC
60x120 cm RC
60x60 cm RC
61x61 cm RC
75x75 cm RC



C1037
C477
*
C165
*
C452
C189
C189
C264



1
1
*
2
1
1
1
1
1



17,000
17,000
*
35,000
*
35,000
17,550
17,750
26,850

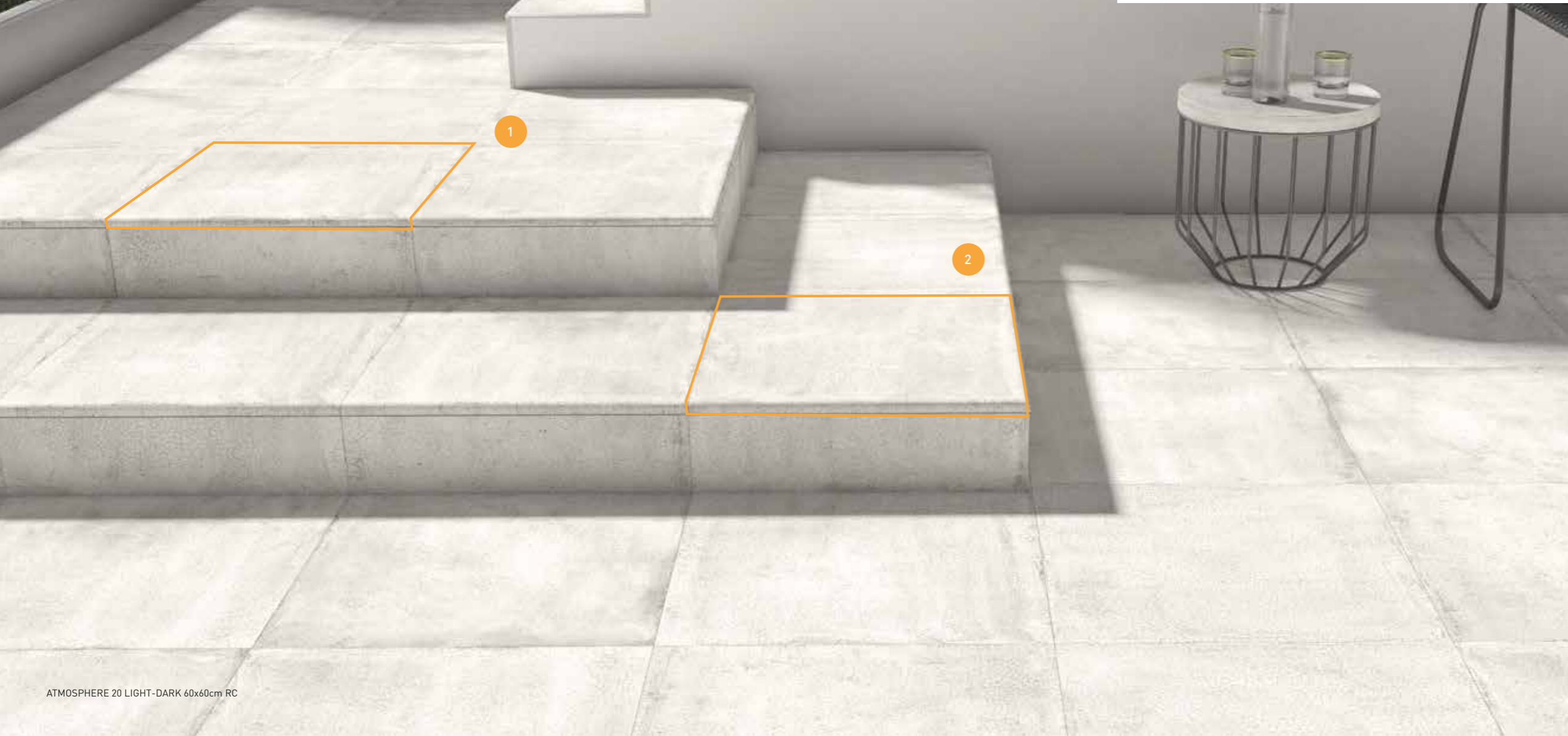

## PELDAÑO ÁNGULO RE

STAIR TREAD ANGLE BULLNOSE BORDER · ECK-STUFFE (ABGERUNDET) · MARCHE D'ANGLE ARRONDIE

2



100x100 cm RC
29,5x120 cm RC
30x30 cm RC
30x60 cm RC
60x120 cm RC
60x60 cm RC
61x61 cm
75x75 cm RC



*
*
*
*
C477
C321
C272
C433



*
2
1
1
1
1
1
4



*
10,520
*
8,800
31,194
18,050
*
28,373



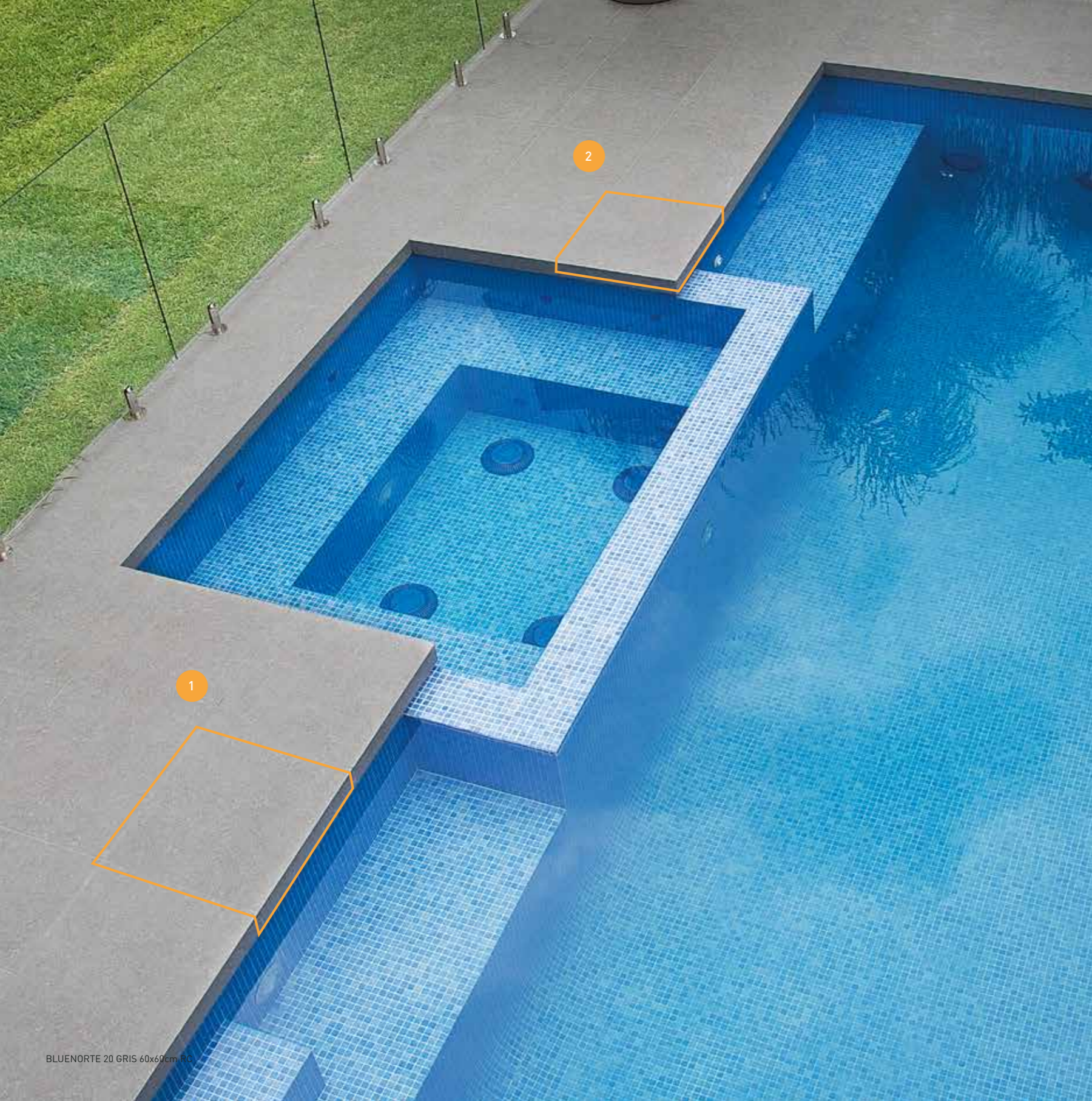

## PELDAÑO ING

STAIR TREAD RECTIFIED BORDER · STUFE (BULZ AUF GEHRUNG) · MARCHE EN ONGLET

OUTDOOR

1



20x120 cm RC	C1037	1	17,000
29,5x120 cm RC	C1037	2	22,000
30x100 cm RC	*	*	*
30x60 cm RC	CP358	3	8,800
30x61 cm	C358	2	8,880
30x75 cm RC	*	2	7,113
60x120 cm RC	C1037	1	35,000
60x60 cm RC	C433	1	17,550
61x61 cm	C433	2	17,750
75x75 cm RC	C700	1	26,850



## PELDAÑO ÁNGULO ING

STAIR TREAD ANGLE RECTIFIED BORDER · ECK-STUFE (BULZ AUF GEHRUNG) · D'ANGLE MARCHE EN ONGLET

2



100x100 cm RC	*	*	*
20x120 cm RC	C1416	1	17,000
29,5x120 cm RC	*	1	11,125
30x30 cm RC	CP321	2	4,510
30x60 cm RC	*	2	8,800
60x120 cm RC	C1416	1	31,194
60x60 cm RC	C716	1	18,050
61x61 cm	C716	1	18,250
75x75 cm RC	C1173	1	28,373







# BORDE ING

COPING RECTIFIED BORDER · BORDE (BULZ AUF GEHRUNG) · BORD EN ONGLET

OUT200R

1



20x100 cm RC  
 20x120 cm RC  
 20x20 cm RC  
 20x60 cm RC  
 20x61 cm RC  
 20x75 cm RC



·  
 C880  
 C153  
 C452  
 C360  
 C539



·  
 1  
 12  
 1  
 4  
 1



·  
 17,000  
 5,130  
 6,300  
 6,400  
 7,860





## REJILLA

POOL GRID - GITTER - GRILLE DE CANIVEAU

OUTDOOR

2



20x100 cm RC		*	*	*
20x120 cm RC		C1107	1	17,000
20x60 cm RC		C524	1	5,050
20x61 cm		C499	1	5,150
20x75 cm RC		C700	1	6,261
29,5x120 cm RC		C1107	1	17,000

## REJILLA ÁNGULO

POOL GRID CORNER - ECK-GITTER - GRILLE DE CANIVEAU ANGULAIRE

Izquierda y derecha - Left and right - Links und rechts - Droite et gauche

3



20X100 cm RC		*	*	*
20x120 cm RC		C2329	1	17,000
20x60 cm RC		C1079	1	4,200
20x61 cm		C1037	4	4,300
20x75 cm RC		C1340	4	5,247
29,5X120 cm RC		*	*	*





## BORDE (h=15)

COPING RECTIFIED BORDER H=5<sup>1/8</sup>" - BORDE (BULZ AUF GEHRUNG) (h=15) - BORD EN ONGLET (h=15)

1



10x100 cm RC  
 10x60 cm RC  
 10x75 cm RC  
 20x120 cm RC  
 20x20 cm RC  
 10x120cm RC



\*  
 C358  
 C558  
 \*  
 C153  
 CP880



\*  
 1  
 2  
 1  
 12  
 1



\*  
 3,150  
 3,900  
 17,000  
 5,130  
 12,00





CONTRACT 20 GREY 60x120cm RC

## BORDE WIN

STEP WIN · BORDE WIN · BORD WIN

OUTDOOR

1



20x100 cm RC
20x120 cm RC
20x20 cm RC
20x60 cm RC
20x75 cm RC



*
C452
C230
C165
C230



*
1
12
4
1



*
17,000
5,130
8,880
22,980

## BORDE RE

COPING BULLNOSE BORDER · BORDE (ABGERUNDET) · BORD ARRONDIE

1



20x100 cm RC
20x120 cm RC
20x60 cm RC
20x61 cm
20x75 cm RC



*
C254
C137
C116
C165



*
1
1
4
1



*
17,000
6,300
6,400
7,860





DOVER 20 GREY 75x75cm RC

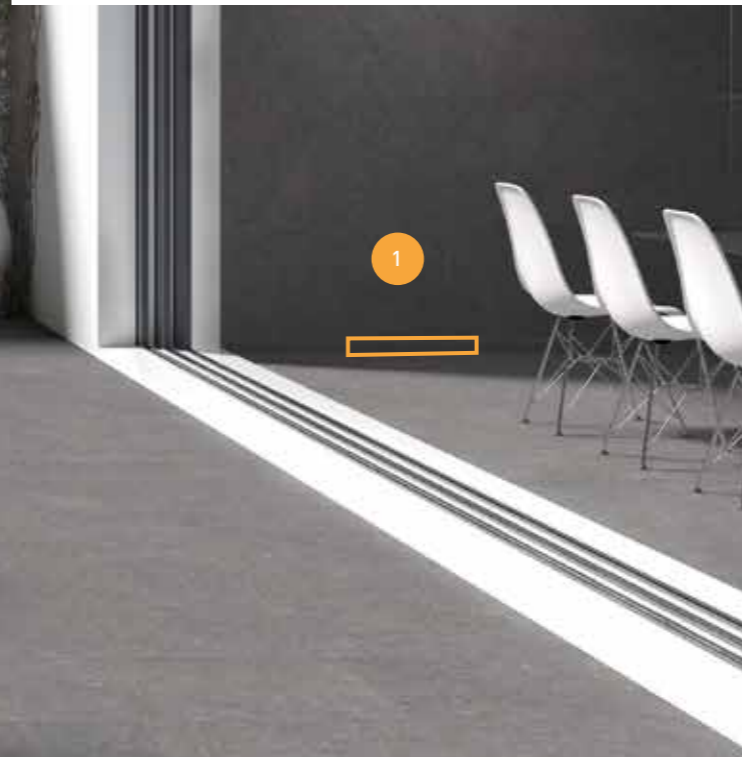

## RODAPIÉ RE

RISER · SOCKEL (ABGERUNDET) · PLINTHE ARRONDIE

OUTDOOR

Izquierda y derecha · Left and right · Links und rechts · Droite et gauche

1



8x100 cm RC  
8x120 cm RC  
8x20 cm RC  
8x60 cm RC  
8x61 cm  
8x75 cm RC



C137  
C165  
C094  
C094  
C094  
C138



2  
2  
2  
5  
5  
2



4,200  
4,600  
2,890  
2,200  
2,300  
3,296

## FOCO

SPOTLIGHT · BELEUCHTUNG · LED PHOTOVOLTAIQUE

Izquierda y derecha · Left and right · Links und rechts · Droite et gauche

2



100x100 cm RC  
60x120 cm RC  
60x60 cm RC  
61x61 cm  
75x75 cm RC



\*  
C2329  
C1300  
C1300  
C1416



\*  
1  
1  
1  
1



\*  
35,000  
18,050  
16,300  
26,850





## BORDE ÁNGULO EXTERIOR RE

OUTDOOR

COPING CORNER BULLNOSE EDGE · ECK-BORDE AUSSEN (ABGERUNDET) · BORD D'ANGLE EXTERIEUR EN ARRONDIE

Izquierda y derecha · Left and right · Links und rechts · Droite et gauche

2



20x100 cm RC	*	*	*
20x120 cm RC	C524	1	17,000
20x20 cm RC	C094	12	5,130
20x60 cm RC	C263	4	5,120
20x61 cm	C244	4	5,200
20x75 cm RC	C358	1	6,050
29,5X120 cm RC	*	*	*



## BORDE ÁNGULO INTERIOR RE

COPING INTERIOR CORNER BULLNOSE EDGE · ECK-BORDE INNEN (ABGERUNDET) · BORD D'ANGLE INTÉRIEUR ARRONDIE

Izquierda y derecha · Left and right · Links und rechts · Droite et gauche

3



20x100 cm RC	*	*	*
20x120 cm RC	C524	1	17,000
20x20 cm RC	C094	12	5,130
20x60 cm RC	C263	4	5,120
20x61 cm	C244	4	5,200
20x75 cm RC	C358	1	6,050
29,5X120 cm RC	*	*	*



\*\* Precio por 2 unidades · Price for 2 units · Preis pro 2 Stück · Prix pour les 2 pièces





## BORDE ÁNGULO EXTERIOR ING

OUTDOOR

COPING EXTERIOR CORNER RECTIFIED EDGE · ECK-BORDE AUSSEN (BULZ AUF GEHRUNG) · BORD D'ANGLE EXTERIEUR EN ONGLET

Izquierda y derecha · Left and right · Links und rechts · Droite et gauche

1



20x100 cm RC	*	*	*
20x120 cm RC	C1416	1	17,000
20x20 cm RC	C298	12	5,130
20x60 cm RC	C770	4	5,120
20x61 cm	C770	4	5,200
20x75 cm RC	C1079	2	6,050
29,5x120 cm RC	C1416	1	17,000



*
C1416
C298
C770
C770
C1079
C1416



*
1
12
4
4
2
1



*
17,000
5,130
5,120
5,200
6,050
17,000

## BORDE ÁNGULO INTERIOR RE

COPING INTERIOR CORNER RECTIFIED EDGE · ECK-BORDE INNEN (BULZ AUF GEHRUNG) · BORD D'ANGLE INTÉRIEUR EN ONGLET

Izquierda y derecha · Left and right · Links und rechts · Droite et gauche

2



20x100 cm RC	*	*	*
20x120 cm RC	C1416	1	17,000
20x20 cm RC	C189	12	5,130
20x60 cm RC	C770	1	5,120
20x61 cm	C770	4	5,200
20x75 cm RC	C1079	1	6,050
29,5x120 cm RC	C1416	1	16,300



*
C1416
C189
C770
C770
C1079
C1416



*
1
12
1
4
1
1



*
17,000
5,130
5,120
5,200
6,050
16,300

\*\* Precio por 2 unidades · Price for 2 units · Preis pro 2 Stück · Prix pour les 2 pièces





BLUENORTE 20 GRIS 75x75cm RC



## BORDE NAT

STEP NAT · BORDE NAT · BORD NAT

OUTDOOR

1



20x100 cm RC  
20x120 cm RC  
20x20 cm RC  
20x60 cm RC  
20x75 cm RC



\*  
C333  
C153  
C137  
C165



\*  
1  
12  
4  
1



\*  
17,000  
5,130  
1,750  
8,880

## PELDAÑO NAT

STEP NAT · STUFE NAT · MARCHE NAT

Izquierda y derecha · Left and right · Links und rechts · Droite et gauche

2



29,5x120 cm RC  
50x100 cm RC  
30x60 cm RC  
37x75 cm RC  
60x120 cm RC  
60x60 cm RC  
75x75 cm RC



C477  
\*  
C165  
\*  
C452  
C189  
C700



1  
\*  
2  
1  
1  
1  
1



17,000  
\*  
8,880  
23,040  
35,000  
17,550  
\*





PISCINAS

SWIMMING POOLS

SCHWIMMBÄDER

PISCINES























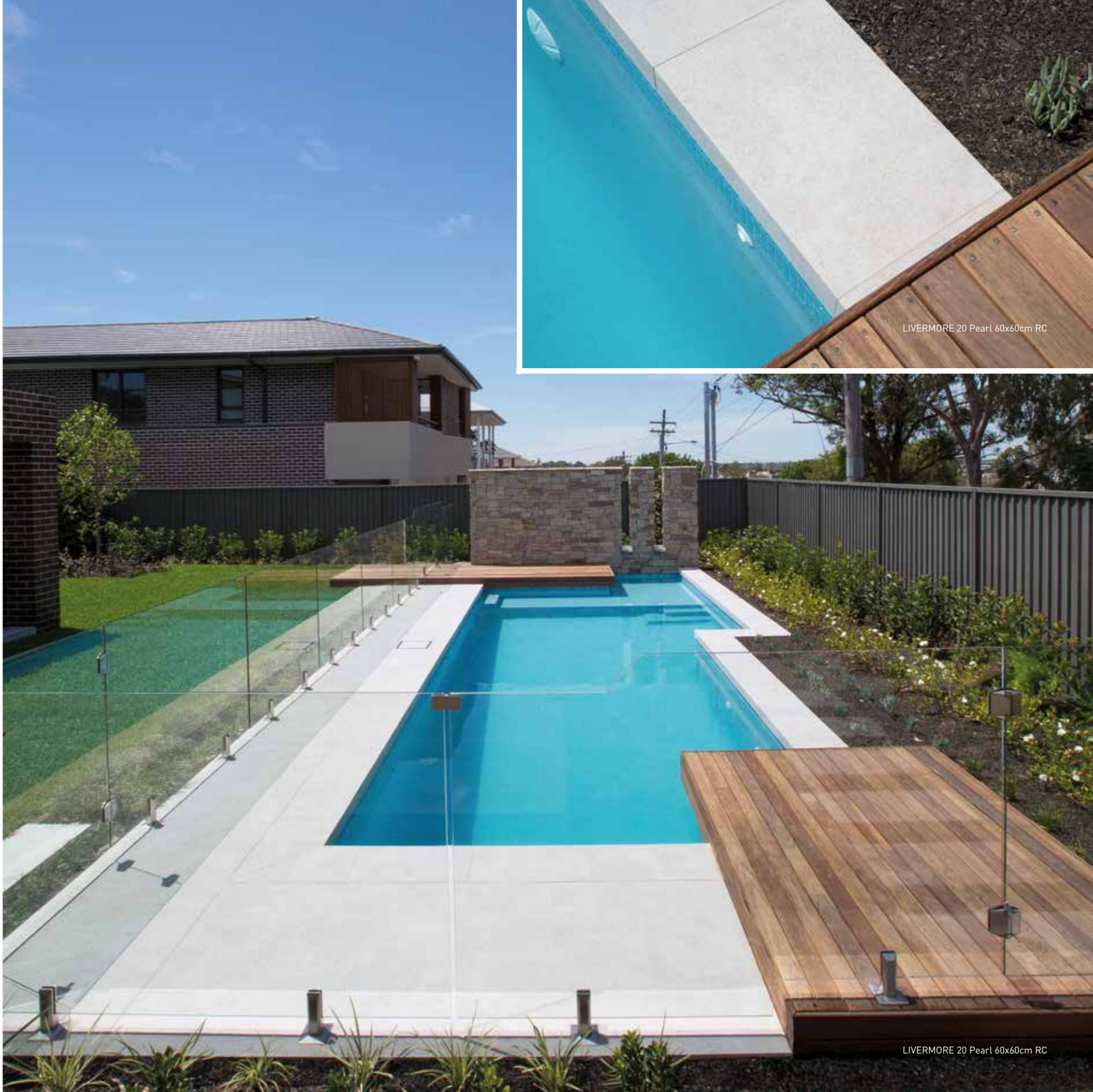
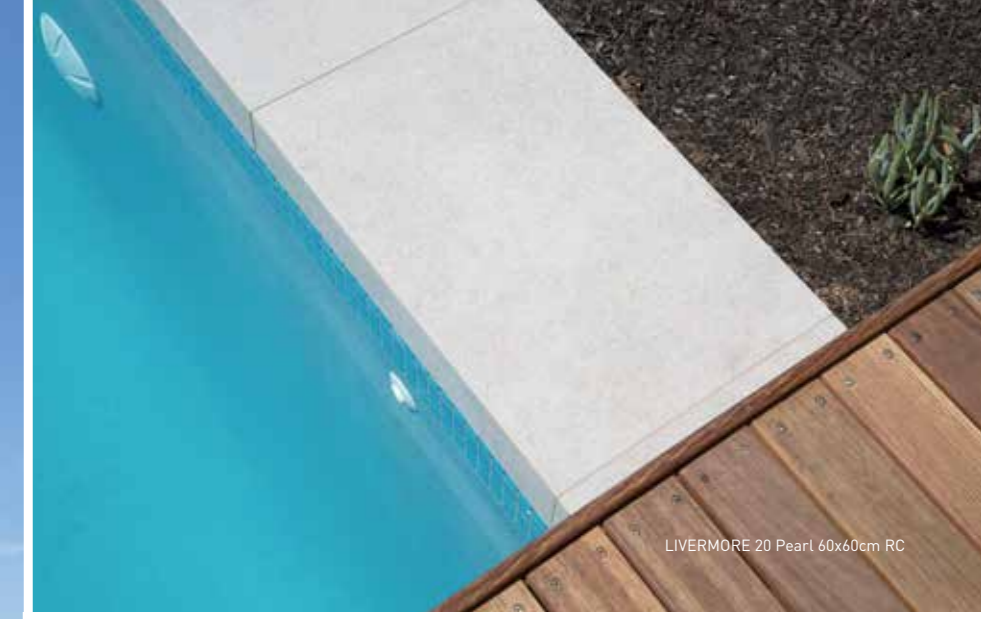





MATERIA 20 Beige 60x60cm RC



MATERIA 20 Beige 60x60cm RC



MATERIA 20 Marfil 60x60cm RC





AXIS 20 White 60x120cm RC



BLACKSHEEP 20 Light 60x120cm RC



DOVER 20 Grey 60x120cm RC



## 6. MODULAR

**MODULAR 60** es la nueva propuesta de **ROCERSA** para decorar los pavimentos de exterior.

Desde el punto de vista estético, cuenta con un perfecto desarrollo de módulos en multi-formato que, al combinarlos entre sí, crea bellas composiciones perfectas para cualquier espacio de exterior.

Desde el punto de vista técnico, se basa en la tecnología **OUTDOOR20**, desarrollo testado en multitud de colecciones de **ROCERSA**, y que se basa en la alta resistencia tanto al deslizamiento como a la rotura de las baldosas.

## 6. MODULAR

**MODULAR 60** is the new proposal of **ROCERSA** to decorate outdoor floors.

From the aesthetic point of view, it has a perfect development of modules in multi-format that, when combined with each other, creates beautiful compositions perfect for any outdoor space.

From the technical point of view, it is based on the technology **OUTDOOR20**, development tested in many collections of **ROCERSA**, and that is based on the high resistance to both sliding and breaking of the tiles.

## 6. MODULAR

**MODULAR 60** est la nouvelle proposition de **ROCERSA** pour décorer les sols à l'extérieur.

D'un point de vue esthétique, elle dispose d'un parfait développement de modules multiformats qui, lorsqu'ils sont combinés entre eux, créent de belles compositions parfaites pour n'importe quel espace extérieur.

D'un point de vue technique, **MODULAR 60** repose sur la technologie **EXTÉRIEUR20** qui a été développée et testée dans une multitude de collections de **ROCERSA**, et qui est basée sur un effet antidérapant renforcé et une haute résistance à la rupture des dalles.

## 6. MODULAR

**MODULAR 60** ist das neue Angebot von **ROCERSA** für die Dekoration von Außenböden.

In ästhetischer Hinsicht bietet es eine perfekte Entwicklung von Modulen in verschiedenen Größen, die in Kombination miteinander schöne Zusammensetzungen schaffen und perfekt für jeden Außenbereich geeignet sind.

In technischer Hinsicht basiert es auf der **OUTDOOR20**-Technologie. Eine Entwicklung, die in einer Vielzahl von Kollektionen von **ROCERSA** getestet wurde und sich durch eine hohe Rutsch- und Bruchfestigkeit der Bodenfliesen auszeichnet.



MODULAR BLUENORTE 20 GRIS



MODULAR DOVER 20 SMOKE





MODULAR AXIS 20 CREAM

**6. MODULAR**

**5 SISTEMAS DE MODULACIÓN**

Máxima versatilidad en las composiciones modulares, alto nivel estético y excelente aprovechamiento de las bases

**4 TEXTURAS DIFERENTES**

Gráficas pétreas para cada estilo y espacio, aseguran un acabado estético y técnico de altas prestaciones

**4 MEDIDAS DIFERENTES**

Cada juego de MODULAR 60 está compuesto por baldosas de 60x60cm, 40x60cm, 40x20cm, y 20x20cm, lo que asegura un perfecto juego visual. Viene todo perfectamente encajado por juegos, aprovechando al máximo cada composición.

**20mm DE ESPESOR**

Gracias a sus 20mm de espesor, MODULAR asegura una alta durabilidad y antideslizamiento en cualquier circunstancia, ya que se nutre de la tecnología OUTDOOR20

**2mm DE JUNTA**

La junta de separación entre baldosas es de 2 milímetros, así aseguramos una perfecta colocación de los módulos.

**6. MODULAR**

**5 MODULATION SYSTEMS**

Maximum versatility in modular compositions, high aesthetic level and excellent use of the bases

**4 DIFFERENT TEXTURES**

Stone graphics for each style and space, ensure a high-tech aesthetic and technical finish

**4 DIFFERENT MEASURES**

Each set of MODULAR 60 is composed of tiles of 60x60cm, 40x60cm, 40x20cm, and 20x20cm, which ensures a perfect visual game. Everything comes perfectly fitted for sets, making the most of each composition

**20mm THICKNESS**

Thanks to its 20mm thick, MODULAR ensures a high durability and anti-skid in any circumstance, as it is based on OUTDOOR20 technology

**2mm JOINT BETWEEN TILES**

The joint between tiles is 2 millimeters, thus ensuring a perfect placement of the modules.

**6. MODULAR**

**5 SYSTÈMES DE MODULATION**

Une polyvalence maximale dans les compositions modulaires, un haut niveau esthétique et une excellente utilisation des bases.

**4 TEXTURES DIFFÉRENTES**

Des graphismes pierreux pour tous les styles et tous les espaces, assurant une finition esthétique et technique avec de hautes performances.

**4 FORMATS DIFFÉRENTS**

Chaque ensemble de MODULAR 60 est composé de dalles de 60 x 60 cm, 40 x 60 cm, 40 x 20 cm et 20 x 20 cm, ce qui garantit un jeu visuel parfait. Tout est parfaitement ajusté grâce aux interstices, en tirant le plus de profit possible de chaque composition.

**20 mm D'ÉPAISSEUR**

Grâce à son épaisseur de 20 mm, MODULAR assure une grande durabilité et un effet antidérapants en toute circonstance, puisqu'il est alimenté par la technologie OUTDOOR20.

**2 mm DE JOINTS**

Le joint de séparation entre les dalles est de 2 millimètres, ce qui garantit un positionnement parfait des modules.

**6. MODULAR**

**5 MODULATIONSSYSTEME**

Maximale Vielseitigkeit in den modularen Zusammensetzungen, hohes ästhetisches Niveau und ausgezeichnete Nutzung der Grundflächen.

**4 VERSCHIEDENE TEXTUREN**

Für jeden Stil und Raum geeignete Steingrafiken sorgen für ein hochwertiges ästhetisches und technisches Finish.

**4 VERSCHIEDENE GRÖSSEN**

Jedes Set von MODULAR 60 besteht aus Bodenfliesen von 60x60 cm, 40x60 cm, 40x20 cm und 20x20 cm, wodurch ein optisch ausgezeichnetes Set gewährleistet wird. Alles wird perfekt in einem Set zusammengestellt, sodass jede Zusammensetzung optimal aufeinander abgestimmt ist.

**20 mm DICKE**

Dank seiner Dicke von 20 mm gewährleistet MODULAR eine hohe Haltbarkeit und Rutschfestigkeit bei allen Bedingungen, da es von der OUTDOOR20-Technologie unterstützt wird.

**2 mm FUGE**

Die Fuge zwischen den Fliesen beträgt 2 Millimeter und gewährleistet so eine perfekte Platzierung der Module.



MODULAR DOVER 20 WHITE





ÍNDICE  
TABLE OF CONTENTS

MADERAS  
WOOD

EVERGLOW

77

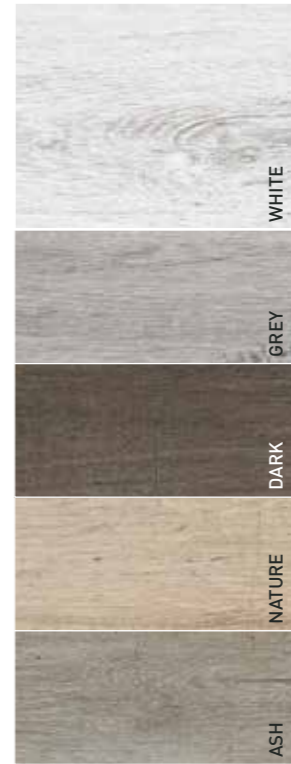

FLOW

85



ICON

93



OLD STATION

99

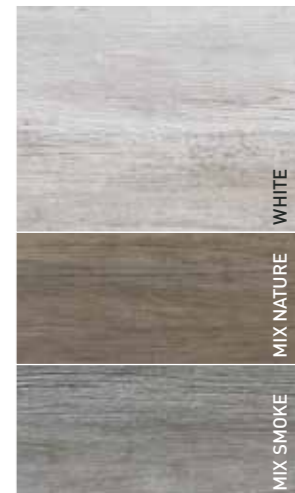

VENICE

105





# EVER GLOW

WHITE

GREY

DARK

NATURE

ASH

## OUTDOOR

29,5x120cm RC • 11,6"x47,2"

PORCELÁNICO  
PORCELAIN TILE









MATE  
20MM ESPESOR  
RECTIFICADO  
MATT  
20MM THICKNESS  
RECTIFIED

→IN←OUT→Collection





EVERGLOW 20 GREY 29,5x120cm RC

  	R001W32428	EVERGLOW 20 DARK ANT RC	29,5x120cm	B 600
  	R001W32434	EVERGLOW 20 WHITE ANT RC	29,5x120cm	B 600
  	R001W32430	EVERGLOW 20 GREY ANT RC	29,5x120cm	B 600

29,5x120cm RC



WHITE









GREY



DARK





  	R001W32432	EVERGLOW 20 NATURE ANT RC	29,5x120cm	B 600
  	R001W32426	EVERGLOW 20 ASH ANT RC	29,5x120cm	B 600

29,5x120cm RC

NATURE

ASH





EVERGLOW 20 NATURE 29,5x120cm RC

→IN←OUT→Collection

Formatos IN&OUT disponibles  
 IN&OUT Sizes available

19,4x120cm RC  
 19,4x120cm RC CTE3/R11

**VARIEDAD GRÁFICA**  
**GRAPHIC VARIETY**

EVERGLOW 20 GREY 29,5x120cm RC



Disponible en todos los colores / Available in all colors





# FLOW

WHITE

LIGHT

SMOKE

MINK

NATURE

## OUTDOOR

29,5x120cm RC • 11,6"x47,2"







**PORCELÁNICO**  
PORCELAIN TILE

**MATE**  
20MM ESPESOR  
RECTIFICADO  
MATT  
20MM THICKNESS  
RECTIFIED

→IN←OUT→Collection





 	RO01W32360	<b>FLOW 20</b> WHITE ANT RC	29,5x120cm	B 600
 	RO01W32252	<b>FLOW 20</b> LIGHT ANT RC	29,5x120cm	B 600
 	RO01W32258	<b>FLOW 20</b> SMOKE ANT RC	29,5x120cm	B 600

29,5x120cm RC



WHITE



LIGHT



SMOKE





📏 📱 📏	R001W32254	<b>FLOW 20 MINK ANT RC</b>	29,5x120cm	B 600
📏 📱 📏	R001W32256	<b>FLOW 20 NATURE ANT RC</b>	29,5x120cm	B 600

29,5x120cm RC

MINK

NATURE





FLOW 20 SMOKE 29,5x120cm RC



→IN←OUT→Collection

Formatos IN&OUT disponibles  
IN&OUT Sizes available

19,4x120cm RC  
19,4x120cm RC CTE3/R11

FLOW  
WHITE | LIGHT | SMOKE | MINK | NATURE

PIEZAS ESPECIALES OUT200R PÁGINA 30  
SPECIAL PIECES PAGE 30

VARIEDAD GRÁFICA  
GRAPHIC VARIETY

FLOW 20 NATURE 29,5x120cm RC



Disponible en todos los colores / Available in all colors





ICON 20 NATURE 29,5x120cm RC



ICON 20 GREY 29,5x120cm RC

NATURE

GREY

# ICON

## OUTDOOR

29,5x120cm RC • 11,6"x47,2"

PORCELÁNICO  
PORCELAIN TILE

MATE  
20MM ESPESOR  
RECTIFICADO  
MATT  
20MM THICKNESS  
RECTIFIED

→IN←OUT→Collection





📏📏📏	RO01W31300	ICON 20 GREY ANT RC	29,5x120cm	B 600
📏📏📏	RO01W31302	ICON 20 NATURE ANT RC	29,5x120cm	B 600

29,5x120cm RC

NATURE

GREY





ICON 20 GREY 29,5x120cm RC

→IN←OUT→Collection

Formatos IN&OUT disponibles  
 IN&OUT Sizes available

29,5x120cm RC

**VARIEDAD GRÁFICA**  
*GRAPHIC VARIETY*

ICON 20 GREY 29,5x120cm RC

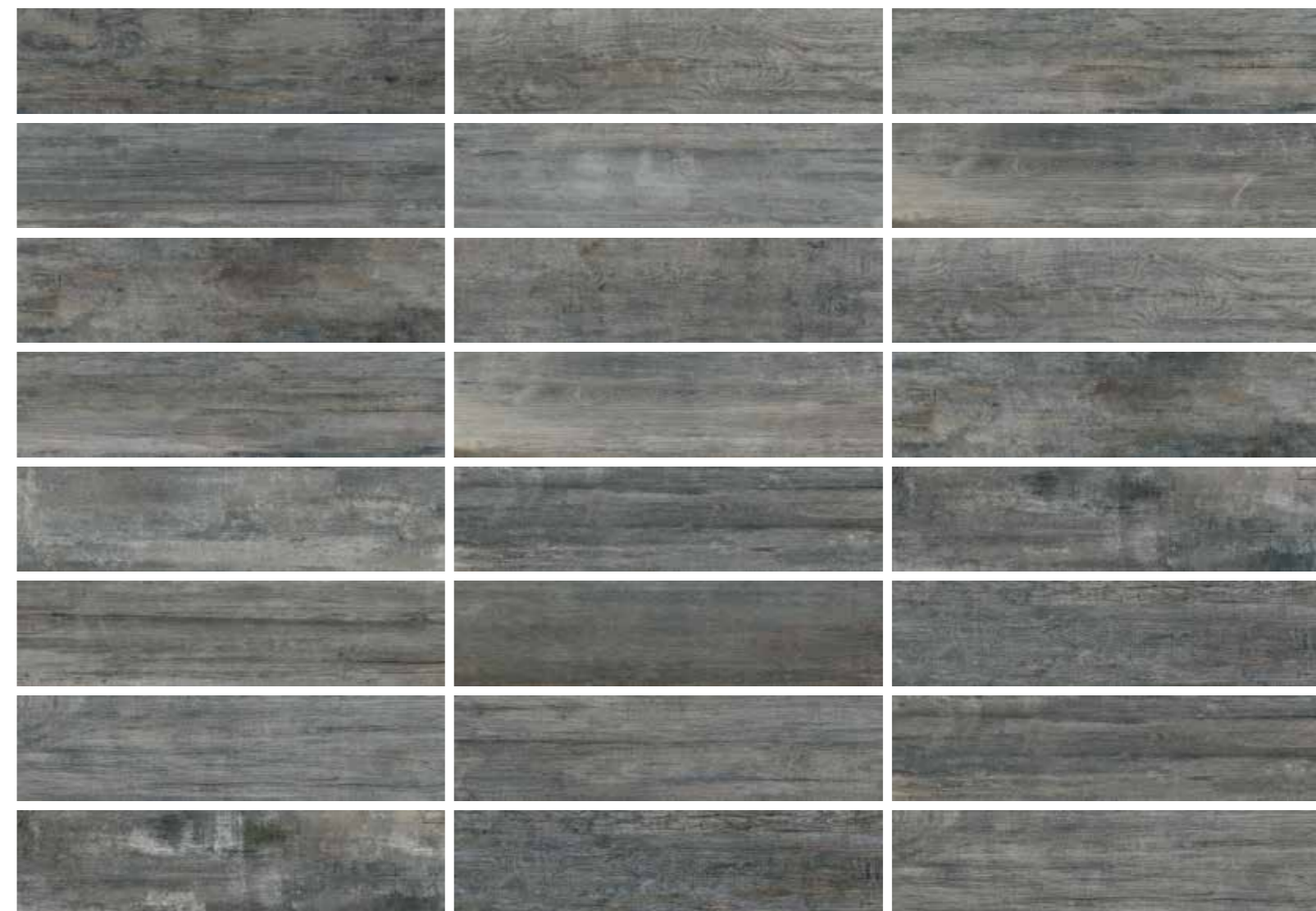

Disponible en todos los colores / Available in all colors





OLD STATION 20 MIX SMOKE 29,5x120cm RC



OLD STATION MIX NATURE 29,5x120cm RC

WHITE

MIX SMOKE

MIX NATURE

# OLD STA TION

**OUTDOOR**

29,5x120cm RC • 11,6"x47,2"



**PORCELÁNICO**  
PORCELAIN TILE

**MATE**  
20MM ESPESOR  
RECTIFICADO  
MATT  
20MM THICKNESS  
RECTIFIED

→IN←OUT→Collection





-  R001W31696 OLD STATION 20 WHITE ANT RC 29,5x120cm B 600
-  R001W31702 OLD STATION 20 MIX SMOKE ANT RC 29,5x120cm B 600

29,5x120cm RC

WHITE

V3

MIX SMOKE

V4



-  R001W31704 OLD STATION 20 MIX NATURE ANT RC 29,5x120cm B 600

29,5x120cm RC

MIX NATURE

V4





OLD STATION WHITE 29,5x120cm RC

→IN←OUT→Collection

Formatos IN&OUT disponibles  
 IN&OUT Sizes available

29,5x120cm RC

**VARIEDAD GRÁFICA**  
**GRAPHIC VARIETY**

OLD STATION 20 WHITE 29,5x120cm RC

OLD STATION WHITE **V3**

OLD STATION MIX SMOKE **V4**

OLD STATION MIX NATURE **V4**



Disponible en todos los colores / Available in all colors





VENICE 20 PEARL 60x60cm RC



VENICE NATURE 60x60cm RC

NATURE

PEARL

GRAFITO

# VE NICE

**OUT200R**

60x60cm RC • 23,6" x 23,6"  
61x61cm • 24" x 24"

**PORCELÁNICO**  
PORCELAIN TILE

**MATE**  
20mm **ESPEJOR**  
**RECTIFICADO**  
MATT  
20mm **THICKNESS**  
RECTIFIED





			R001W31176	VENICE 20 NATURE ANT RC	60x60cm	B 410
			R001W31172	VENICE 20 PEARL ANT RC	60x60cm	B 410
			R001W31174	VENICE 20 GRAFITO ANT RC	60x60cm	B 410
			R001WS5182	VENICE 20 NATURE ANT	61x61cm	B 360
			R001WS5178	VENICE 20 PEARL ANT	61x61cm	B 360
			R001WS5180	VENICE 20 GRAFITO ANT	61x61cm	B 360

61x61cm  
60x60cm RC

NATURE

PEARL

GRAFITO



VARIEDAD GRÁFICA  
GRAPHIC VARIETY

VENICE 20 NATURE 60x60cm RC

Disponibile en Modular  
Modular Avalaible

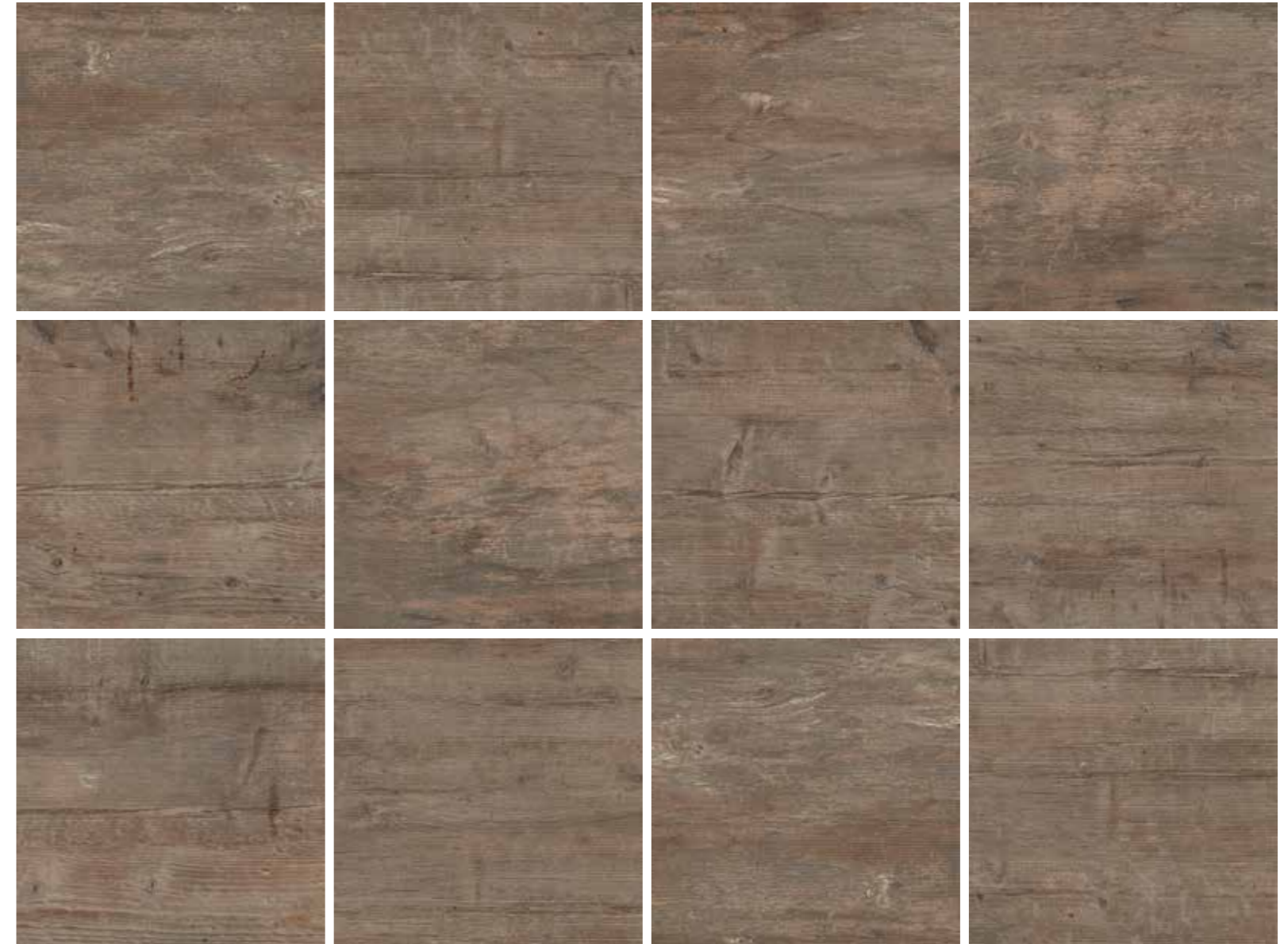

Disponibile en todos los colores / Avalaible in all colors



ÍNDICE  
TABLE OF CONTENTS

CEMENTOS  
CONCRETE

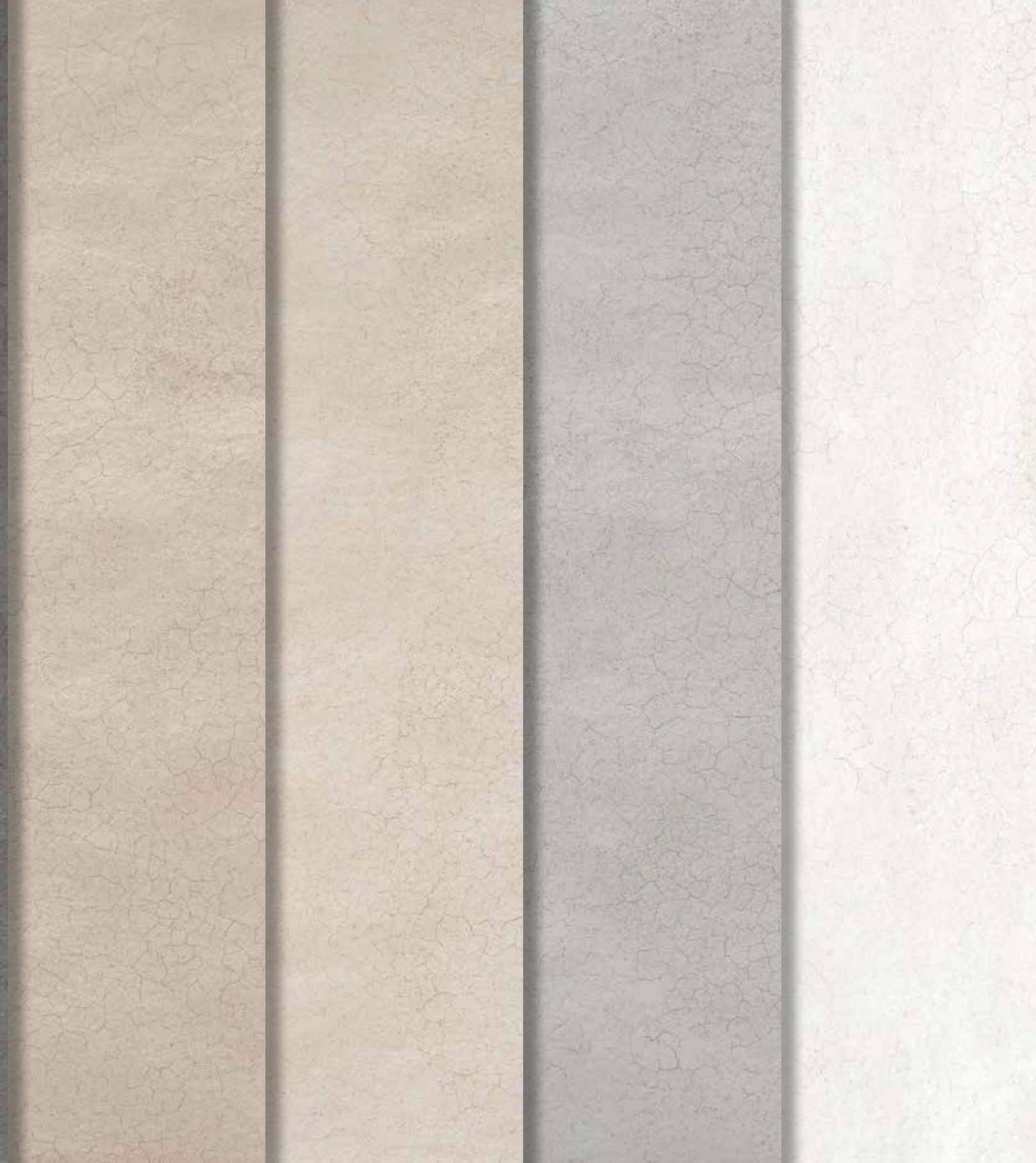

ASTMOSPHERE 111



BELFORT 119



CONTRACT 125



ETERNAL STONE 133

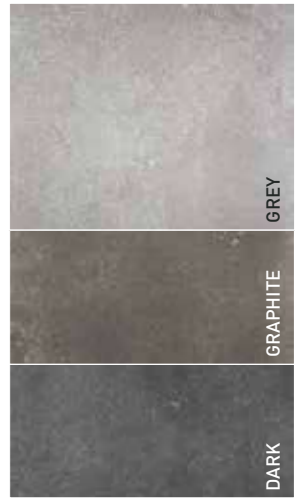

MAKE UP 145



MUSTANG 167



SYNERGY 175







# AT MOS PHE RE

LIGHT-DARK

SMOKE-DARK

MINK-DARK

TAUPE-DARK

ANTHRACITE-DARK

**OUTDOOR**

60x60cm RC • 23,6" x 23,2"  
61x61cm • 24" x 24"  
60x120cm RC • 23,6" x 47,2"

**PORCELÁNICO**  
PORCELAIN TILE

**MATE**  
20MM ESPESOR  
RECTIFICADO  
MATT  
20MM THICKNESS  
RECTIFIED

→IN←OUT→Collection





			RO01W32338	ATMOSPHERE 20 LIGHT-DARK ANT RC	60x60cm	B 410
			RO01W56886	ATMOSPHERE 20 LIGHT-DARK ANT	61x61cm	B 360
			RO01W32328	ATMOSPHERE 20 LIGHT-DARK ANT RC	60x120cm	B 600
			RO01W32342	ATMOSPHERE 20 SMOKE-DARK ANT RC	60x60cm	B 410
			RO01W56890	ATMOSPHERE 20 SMOKE-DARK ANT	61x61cm	B 360
			RO01W32332	ATMOSPHERE 20 SMOKE-DARK ANT RC	60x120cm	B 600
			RO01W32336	ATMOSPHERE 20 ANTHRACITE-DARK ANT RC	60x60cm	B 410
			RO01W56884	ATMOSPHERE 20 ANTHRACITE-DARK ANT	61x61cm	B 360
			RO01W32326	ATMOSPHERE 20 ANTHRACITE-DARK ANT RC	60x120cm	B 600



ATMOSPHERE 20 ANTHRACITE-DARK

ATMOSPHERE 20 SMOKE-DARK

ATMOSPHERE 20 LIGHT-DARK





			RO01W32340	ATMOSPHERE 20 MINK-DARK ANT RC	60x60cm	B 410
			RO01WS6888	ATMOSPHERE 20 MINK-DARK ANT	61x61cm	B 360
			RO01W32330	ATMOSPHERE 20 MINK-DARK ANT RC	60x120cm	B 600
			RO01W32344	ATMOSPHERE 20 TAUPE-DARK ANT RC	60x60cm	B 410
			RO01WS6892	ATMOSPHERE 20 TAUPE-DARK ANT	61x61cm	B 360
			RO01W32334	ATMOSPHERE 20 TAUPE-DARK ANT RC	60x120cm	B 600



ATMOSPHERE 20 TAUPE-DARK

ATMOSPHERE 20 MINK-DARK





ATMOSPHERE 7 MINK-SOFT 40x120cm RC · ATMOSPHERE 7 LIGHT-SOFT 40x120cm RC · ATMOSPHERE 20 TAUPE-MEDIUM 60x120cm RC

**V1 OUT200R**

**ATMOSPHERE**  
LIGHT | SMOKE | MINK | TAUPE | ANTHRACITE

PIEZAS ESPECIALES **OUT200R** PÁGINA 30  
SPECIAL PIECES **OUT200R** PAGE 30

→IN←OUT→Collection

Formatos IN&OUT disponibles  
IN&OUT Sizes available



Disponible en Modular  
 Modular Available

**VARIEDAD GRÁFICA**  
GRAPHIC VARIETY

ATMOSPHERE 20 SMOKE-DARK 60x60cm RC

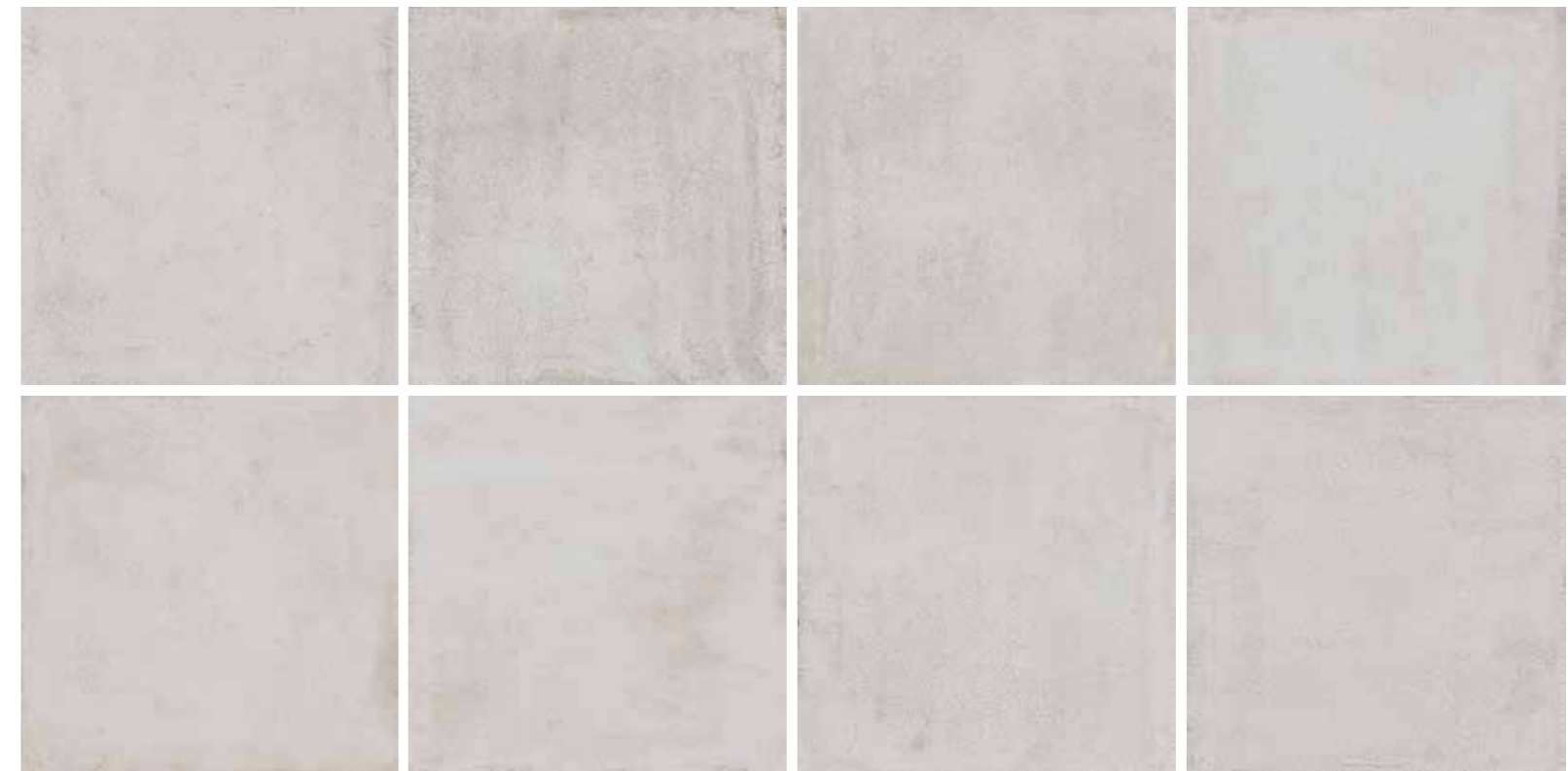

Disponible en todos los colores / Available in all colors





# BEL FORT

GRIS

GRAFITO

## OUTDOOR

60x60cm RC • 23,6" x 23,2"  
61x61cm • 24" x 24"  
75x75cm RC • 29,5" x 29,5"

**PORCELÁNICO**  
PORCELAIN TILE

**MATE**  
**RECTIFICADO**  
MATT  
RECTIFIED

**MATE**  
**20MM ESPESOR**  
**RECTIFICADO**  
MATT  
20MM THICKNESS  
RECTIFIED

→IN←OUT→Collection





**OUT200R**

**BELFORT**  
GRIS | GRAFITO

	R001W31114	<b>BELFORT 20</b> GRIS ANT RC	60x60cm	B 410
	R001WS5068	<b>BELFORT 20</b> GRIS ANT	61x61cm	B 360
	R001W31062	<b>BELFORT 20</b> GRIS ANT RC	75x75cm	B 524
	R001W31116	<b>BELFORT 20</b> GRAFITO ANT RC	60x60cm	B 410
	R001WS5070	<b>BELFORT 20</b> GRAFITO ANT	61x61cm	B 360
	R001W31064	<b>BELFORT 20</b> GRAFITO ANT RC	75x75cm	B 524

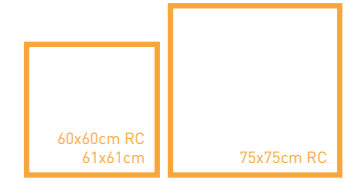

GRIS



GRAFITO





BELFORT 20 GRIS 60x60cm



**BELFORT**  
BLANCO | TOSTADO | GRIS | GRAFITO

PIEZAS ESPECIALES **OUT200R** PÁGINA 30  
SPECIAL PIECES **OUT200R** PAGE 30

### →IN←OUT→Collection

Formatos IN&OUT disponibles  
IN&OUT Sizes available

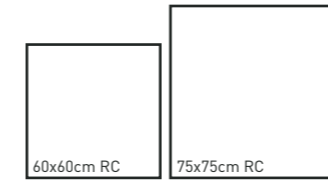

Disponibile en Modular  
Modular Available

**VARIEDAD GRÁFICA**  
*GRAPHIC VARIETY*

**BELFORT 20** GREY 60x60cm



Disponibile en todos los colores / Available in all colors



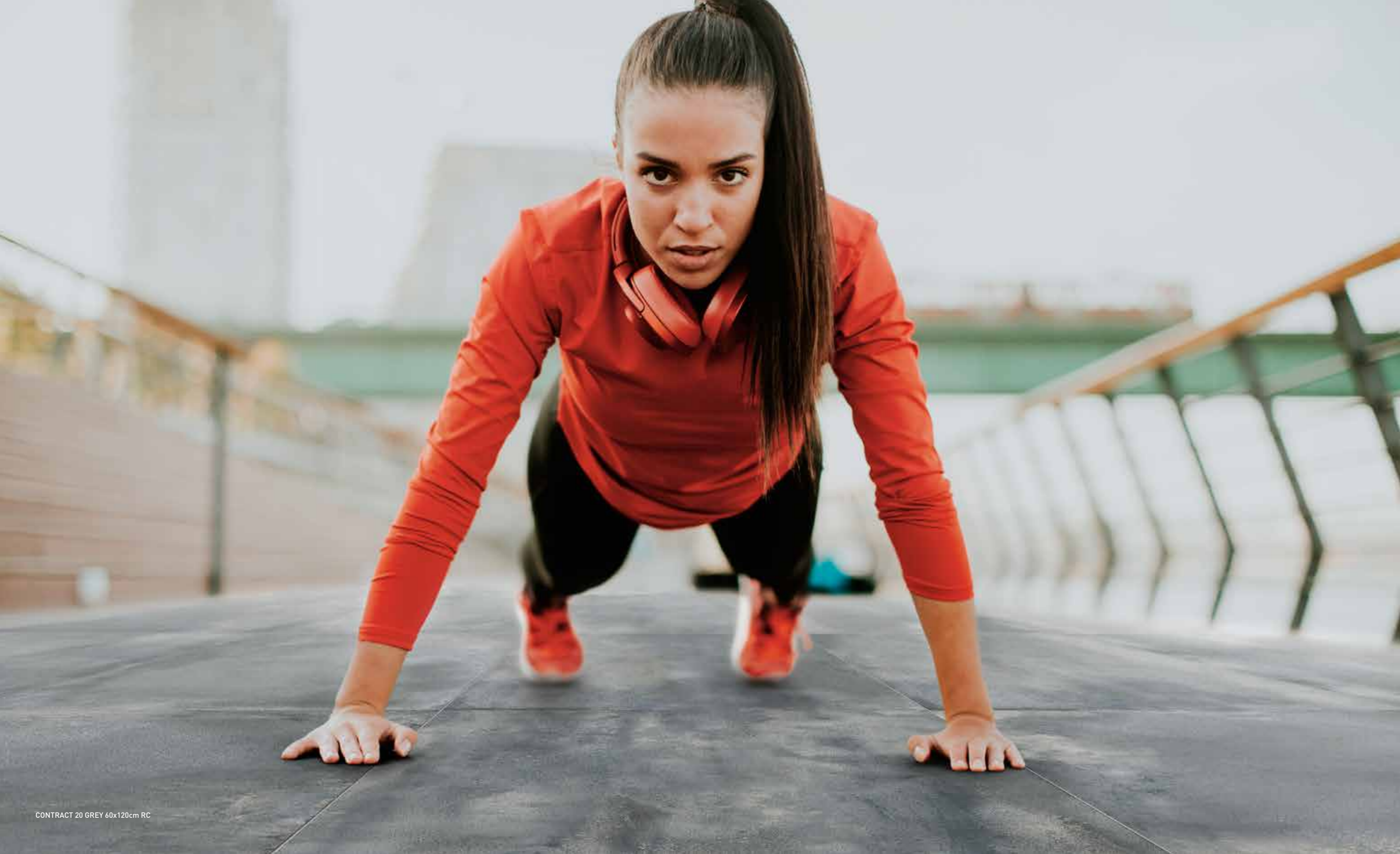

# CONTRACT

WHITE

GREY

GRAFITO

**OUTDOOR**

60x120cm RC • 23,6" x 47,2"

**PORCELÁNICO**  
PORCELAIN TILE

**MATE**  
20MM ESPESOR  
RECTIFICADO  
MATT  
20MM THICKNESS  
RECTIFIED

→IN←OUT→Collection





WHITE

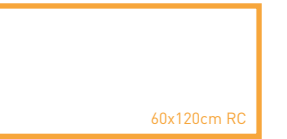

GRAFITO







60x120cm RC

GREY





CONTRACT 20 WHITE 60x120cm RC



CONTRACT  
WHITE | GREY | GRAFITO

### →IN←OUT→Collection

Formatos IN&OUT disponibles  
IN&OUT Sizes available



PIEZAS ESPECIALES **OUT200R** PÁGINA 30  
SPECIAL PIECES **OUT200R** PAGE 30

VARIEDAD GRÁFICA  
GRAPHIC VARIETY

CONTRACT 20 GREY 60x120cm RC



Disponible en todos los colores / Available in all colors





ETERNAL STONE 20 GRAPHITE 100x100cm RC



ETERNAL STONE 20 DARK 100x100cm RC

# ETERNAL STONE

GREY

GREY

GRAPHITE

GRAPHITE

DARK

DARK

**OUTDOOR**

20x20cm RC • 7,9"x7,9"  
 60x60cm RC • 23,6"x23,6"  
 100x100cm RC • 39,4"x39,4"

**PORCELÁNICO**  
 PORCELAIN TILE

**MATE**  
 20MM ESPESOR  
 RECTIFICADO  
 MATT  
 20MM THICKNESS  
 RECTIFIED

→IN←OUT→Collection





ETERNAL STONE 20 GREY 100x100cm RC

						<b>OUT200R</b>				
							R001W3067	<b>ETERNAL STONE 20 GREY RC</b>	60x60cm	B 410
							R001W3069	<b>ETERNAL STONE 20 GRAPHITE RC</b>	60x60cm	B 410
							R001W3065	<b>ETERNAL STONE 20 DARK RC</b>	60x60cm	B 410
							R001W32753	<b>ETERNAL STONE 20 GREY RC</b>	100x100cm	B 600
							R001W32755	<b>ETERNAL STONE 20 GRAPHITE RC</b>	100x100cm	B 600
							R001W32751	<b>ETERNAL STONE 20 DARK RC</b>	100x100cm	B 600

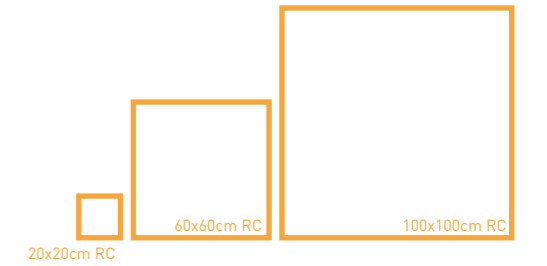

GREY



GRAPHITE

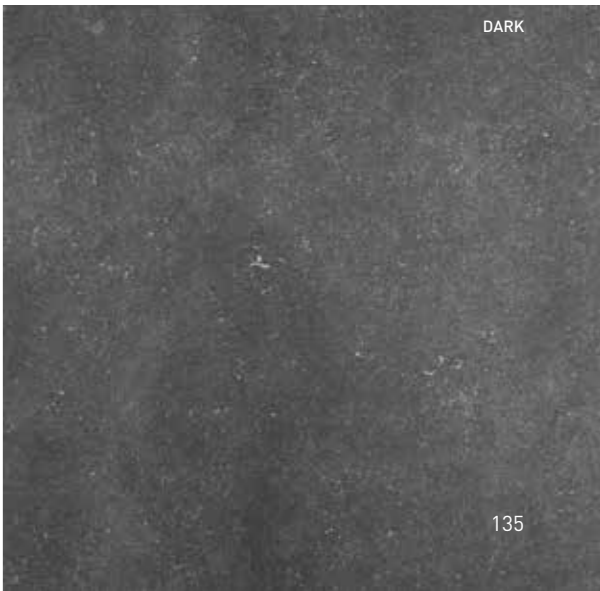

DARK





ETERNAL STONE 20 DARK 100x100cm RC



ETERNAL STONE  
GREY | GRAPHITE | DARK

PIEZAS ESPECIALES **OUT200R** PÁGINA 30  
SPECIAL PIECES **OUT200R** PAGE 30

→IN←OUT→Collection

Formatos IN&OUT disponibles  
IN&OUT Sizes available

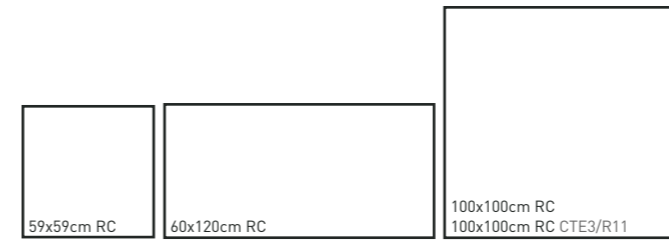

VARIEDAD GRÁFICA  
GRAPHIC VARIETY

ETERNAL STONE 20 GRAPHITE 100x100cm RC

Disponibile en Modular  
Modular Available

Disponibile en Hidrocorte  
Hydrocutting Available

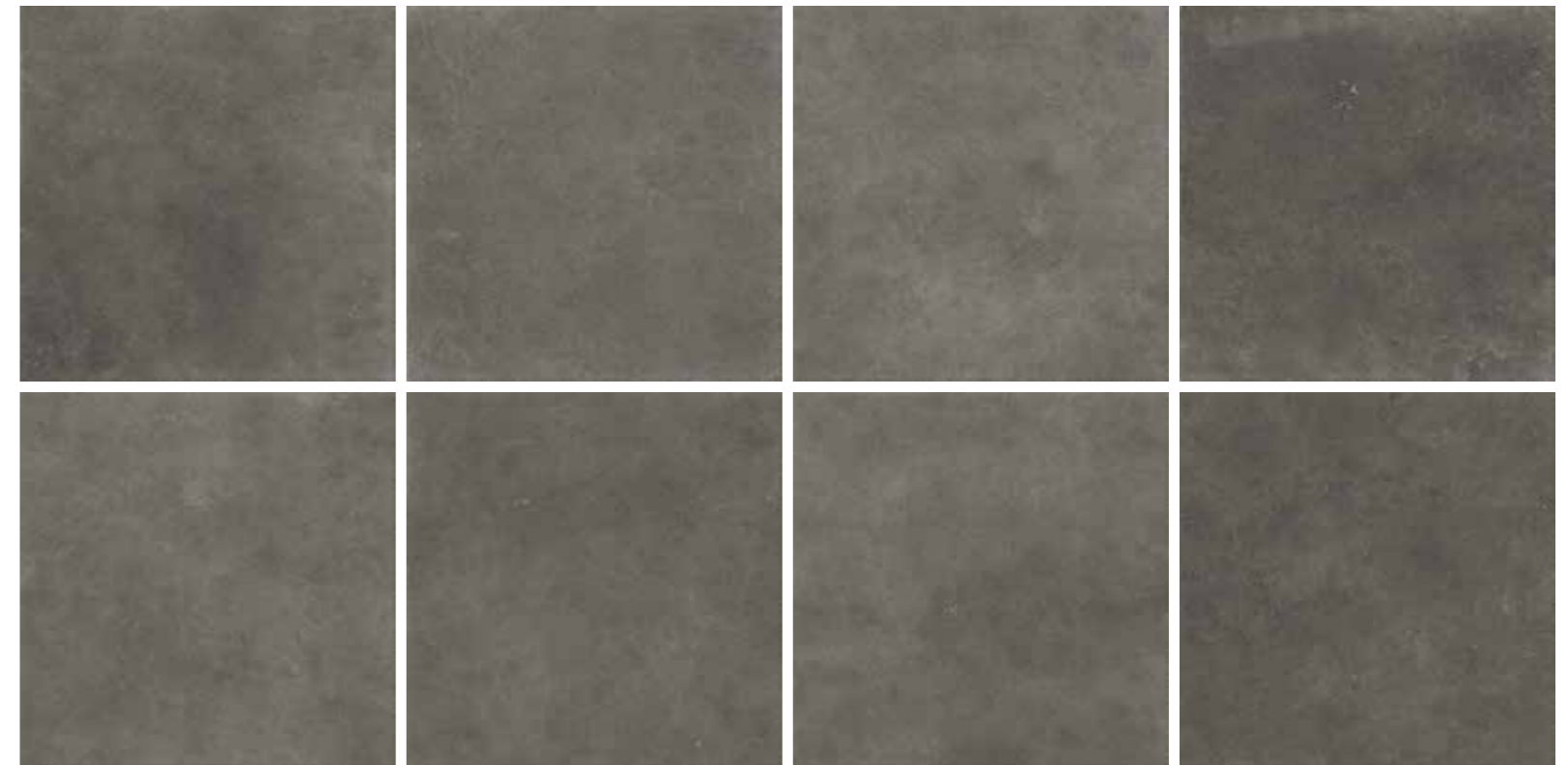

Disponibile en todos los colores / Available in all colors









 R001W33006 **ETERNAL STONE 20 GREY RC** 20x20cm B 671



 R001W33004 **ETERNAL STONE 20 GRAPHITE RC** 20x20cm B 671





 R001W33008 **ETERNAL STONE 20 DARK RC** 20x20cm B 671

**VARIEDAD GRÁFICA**  
*GRAPHIC VARIETY*

ETERNAL STONE **20** DARK 20x20cm RC



*Disponible en todos los colores / Available in all colors*





# MAKE UP





## OUTDOOR

20x20cm RC • 7,9" x 7,9"  
60x120cm RC • 23,6" x 47,2"  
100x100cm RC • 39,4" x 39,4"

**PORCELÁNICO**  
PORCELAIN TILE



**MATE**  
20MM ESPESOR  
RECTIFICADO  
MATT  
20MM THICKNESS  
RECTIFIED

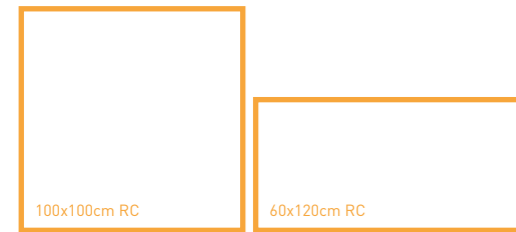

	RO01W32607	MAKE UP 20 WHITE RC	60x120cm	B 600
	RO01W32749	MAKE UP 20 WHITE RC	100x100cm	B 600



WHITE

	RO01W32605	MAKE UP 20 GREY RC	60x120cm	B 600
	RO01W32745	MAKE UP 20 GREY RC	100x100cm	B 600

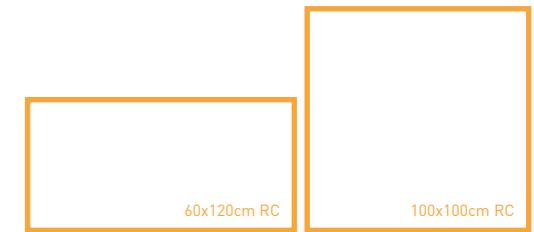







GREY



MAKE UP  
WHITE | GREY | DARK | MINK



-    R001W32609 MAKE UP 20 DARK RC 60x120cm B 600
-    R001W32743 MAKE UP 20 DARK RC 100x100cm B 600

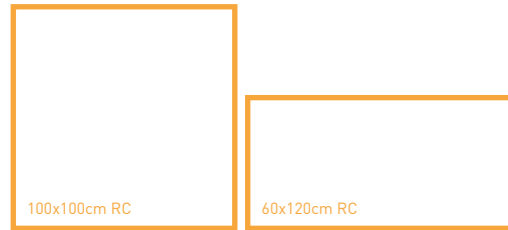







DARK



MAKE UP  
WHITE | GREY | DARK | MINK



-    R001W32615 MAKE UP 20 MINK RC 60x120cm B 600
-    R001W32747 MAKE UP 20 MINK RC 100x100cm B 600

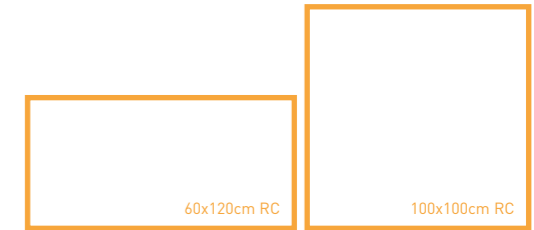

MINK





- R001W32978 **MAKE UP HIDRA OUT 20 COLD RC** 60x60cm B 410
- R001W32980 **MAKE UP HIDRA OUT 20 WARM RC** 60x60cm B 410



MAKE UP HIDRA 20 COLD 60x60cm RC







MAKE UP 20 GREY 100x100cm RC - MAKE UP GREY 100x100cm RC

 **OUT200R**

**MAKE UP**  
WHITE | GREY | DARK | MINK

PIEZAS ESPECIALES **OUT200R** PÁGINA 30  
SPECIAL PIECES **OUT200R** PAGE 30

**VARIEDAD GRÁFICA**  
*GRAPHIC VARIETY*

**MAKE UP 20** GREY 100x100cm RC

 Disponible en Hidrocorte  
*Hydrocutting Available*

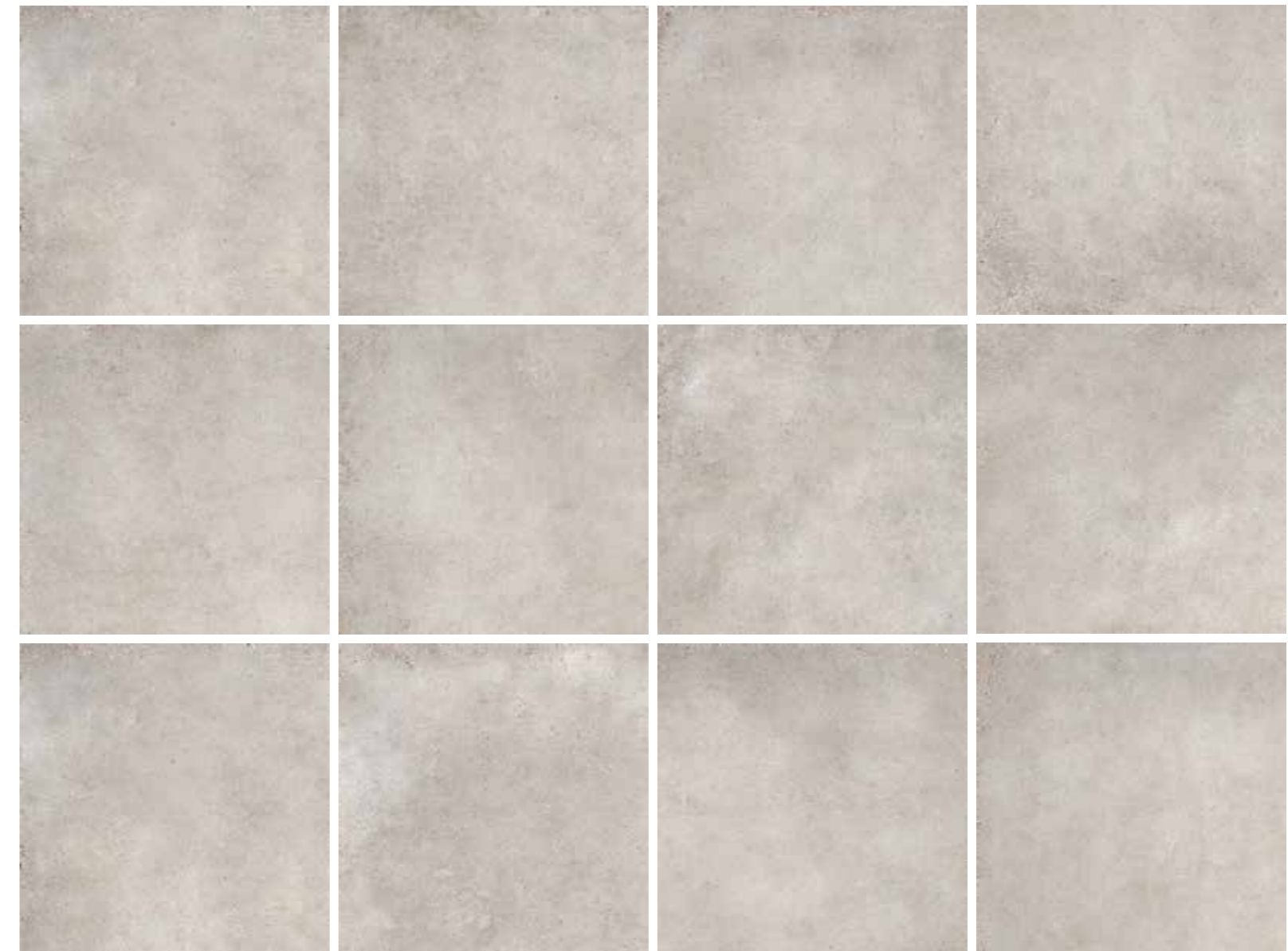

*Disponible en todos los colores / Available in all colors*









 R001W32593 **MAKE UP 20 WHITE RC** 20x20cm B 600



 R001W32589 **MAKE UP 20 GREY RC** 20x20cm B 600





 R001W32591 **MAKE UP 20 DARK RC** 20x20cm B 600



 R001W32599 **MAKE UP 20 MINK RC** 20x20cm B 600





MAKE UP 20 MINK 20x20cm RC

**VARIEDAD GRÁFICA**  
*GRAPHIC VARIETY*

**MAKE UP 20** MINK 20x20cm RC



*Disponible en todos los colores / Available in all colors*





 R001W32573 **MAKE UP HIDRA 20 COLD RC** 20x20cm B 600



 R001W32575 **MAKE UP HIDRA 20 WARM RC** 20x20cm B 600





MAKE UP HIDRA 20 WARM 20x20cm RC

**VARIEDAD GRÁFICA**  
*GRAPHIC VARIETY*

MAKE UP HIDRA 20 WARM 20x20cm RC



Disponible en todos los colores / Available in all colors





MUSTANG 20 GREY 60x60cm RC



MUSTANG 20 NOCE 6'x60cm RC

WHITE

GREY

MINK

NOCE

ANTHRACITE

# MUS TANG

## OUTDOOR

60x60cm RC • 23,6" x 23,2"  
61x61cm • 24" x 24"  
75x75cm RC • 29,5" x 29,5"

**PORCELÁNICO**  
PORCELAIN TILE

**MATE**  
20MM ESPESOR  
RECTIFICADO  
MATT  
20MM THICKNESS  
RECTIFIED

→IN←OUT→Collection





			R001W31802	MUSTANG 20 MINK ANT RC	60x60cm	B 410
			R001WS6087	MUSTANG 20 MINK ANT	61x61cm	B 360
			R001W31926	MUSTANG 20 MINK ANT RC	75x75cm	B 524
			R001W31800	MUSTANG 20 NOCE ANT RC	60x60cm	B 410
			R001WS6085	MUSTANG 20 NOCE ANT	61x61cm	B 360
			R001W31924	MUSTANG 20 NOCE ANT RC	75x75cm	B 524

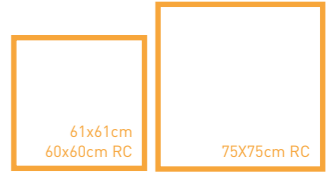

MUSTANG 20 MINK 75x75cm RC



MINK



NOCE





	R001W31798	MUSTANG 20 WHITE ANT RC	60x60cm	B 410
	R001WS6083	MUSTANG 20 WHITE ANT	61x61cm	B 360
	R001W31920	MUSTANG 20 WHITE ANT RC	75x75cm	B 524
	R001W31804	MUSTANG 20 GREY ANT RC	60x60cm	B 410
	R001WS6089	MUSTANG 20 GREY ANT	61x61cm	B 360
	R001W31928	MUSTANG 20 GREY ANT RC	75x75cm	B 524
	R001W31796	MUSTANG 20 ANTHRACITE ANT RC	60x60cm	B 410
	R001WS6081	MUSTANG 20 ANTHRACITE ANT	61x61cm	B 360
	R001W31922	MUSTANG 20 ANTHRACITE ANT RC	75x75cm	B 524

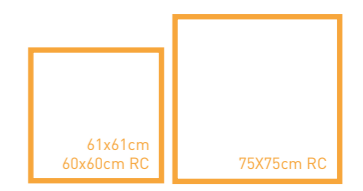

WHITE

GREY

ANTHRACITE





MUSTANG 20 WHITE 60x60cm RC

**OUT200R**

**MUSTANG**  
WHITE | GREY | MINK | NOCE | ANTHRACITE

PIEZAS ESPECIALES **OUT200R** PÁGINA 30  
SPECIAL PIECES **OUT200R** PAGE 30

→IN←OUT→Collection

Formatos IN&OUT disponibles  
IN&OUT Sizes available

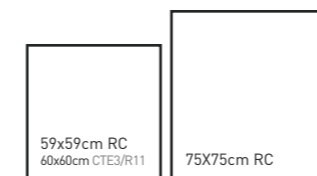

Disponible en Modular  
 Modular Available

**VARIEDAD GRÁFICA**  
GRAPHIC VARIETY

**MUSTANG 20** WHITE 60x60cm RC

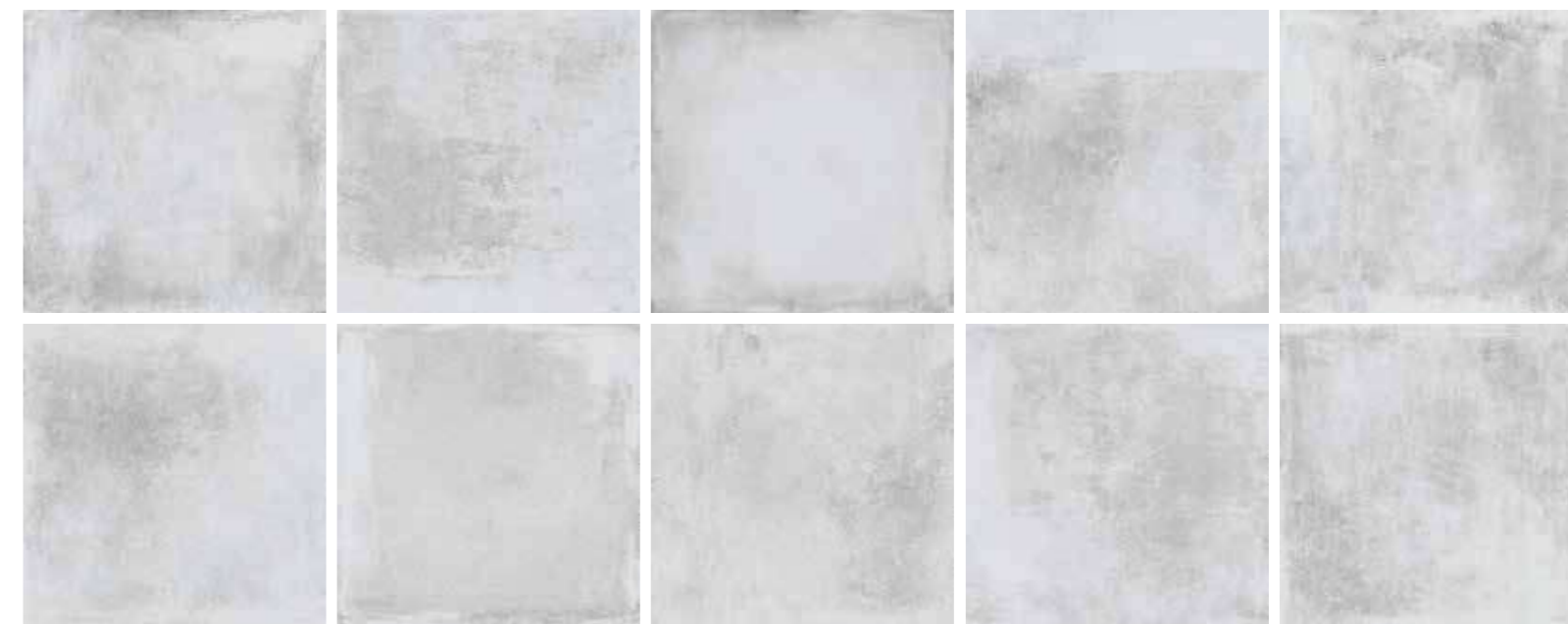

Disponible en todos los colores / Available in all colors





SYNERGY 20 PEARL 60x60cm RC



SYNERGY 20 BLACK 60x60cm RC

# SYNERGY

PEARL

GREY

BLACK

SAND

BROWN

**OUTDOOR**

60x60cm RC • 23,6" x 23,2"  
61x61cm • 24" x 24"

**PORCELÁNICO**  
PORCELAIN TILE

**MATE**  
20MM ESPESOR  
RECTIFICADO  
MATT  
20MM THICKNESS  
RECTIFIED

→IN←OUT→Collection





			R001W31184	SYNERGY 20 SAND ANT RC	60x60cm	B 410
			R001WS5190	SYNERGY 20 SAND ANT	61x61cm	B 360
			R001W31182	SYNERGY 20 BROWN ANT RC	60x60cm	B 410
			R001WS5188	SYNERGY 20 BROWN ANT	61x61cm	B 360

61x61cm  
 60x60cm RC

SAND

BROWN



	R001W31180	SYNERGY 20 PEARL ANT RC	60x60cm	B 410
	R001WS5186	SYNERGY 20 PEARL ANT	61x61cm	B 360
	R001W31178	SYNERGY 20 GREY ANT RC	60x60cm	B 234
	R001WS5184	SYNERGY 20 GREY ANT	61x61cm	B 360
	R001W31186	SYNERGY 20 BLACK ANT RC	60x60cm	B 410
	R001WS5192	SYNERGY 20 BLACK ANT	61x61cm	B 360



PEARL

GREY

BLACK

**→IN←OUT→Collection**

Formatos IN&OUT disponibles  
IN&OUT Sizes available



Disponible en Modular  
Modular Available

PIEZAS ESPECIALES **OUT200R** PÁGINA 30  
SPECIAL PIECES **OUT200R** PAGE 30

**VARIEDAD GRÁFICA**  
GRAPHIC VARIETY

**SYNERGY 20 BROWN 60x60cm RC**

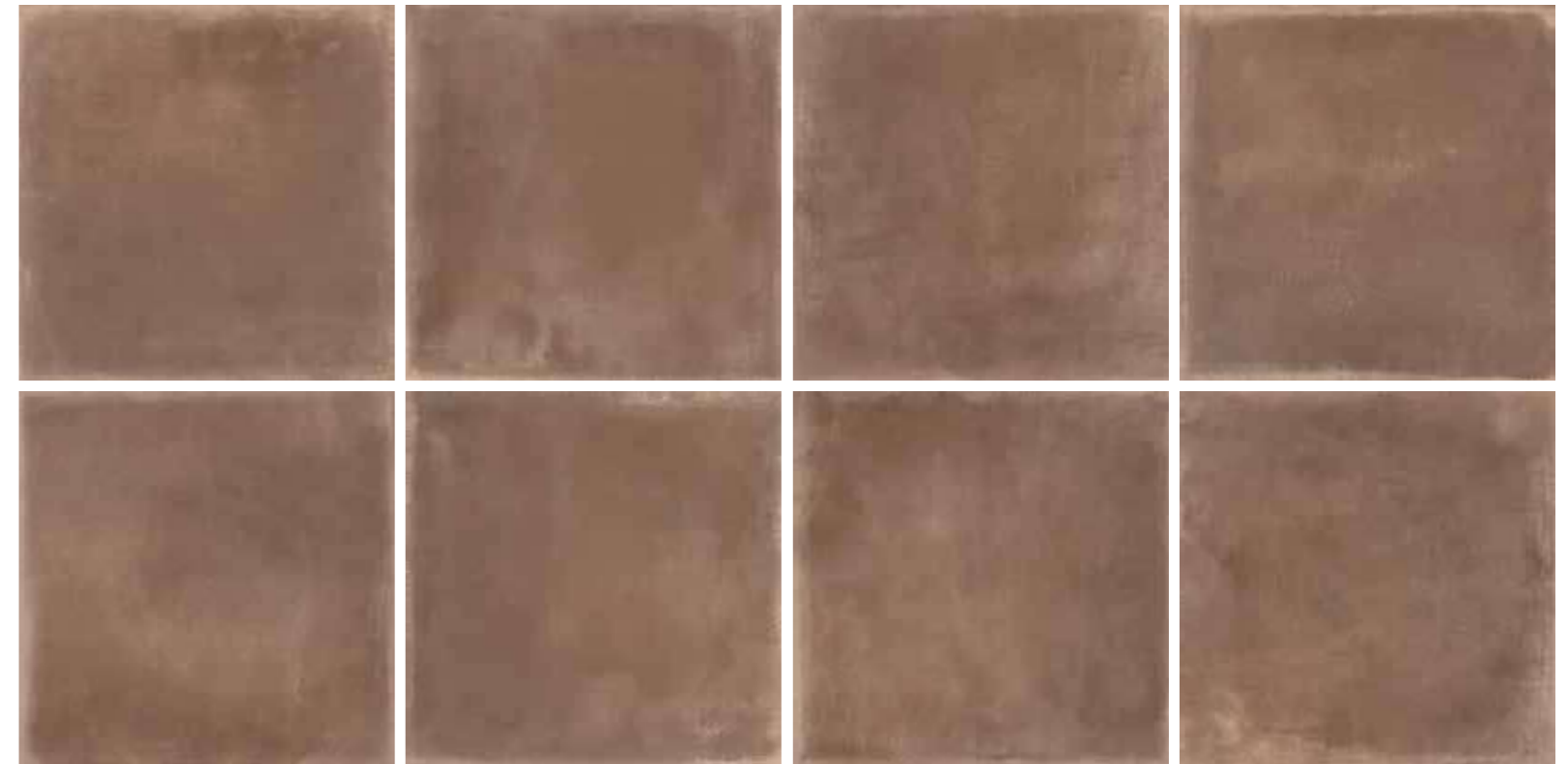

Disponible en todos los colores / Available in all colors



ÍNDICE  
TABLE OF CONTENTS

PIEDRAS  
STONE

ARUBA 183



AXIS 191



BLACKSHEEP 199



BLUENORTE 205



BRUGES 211

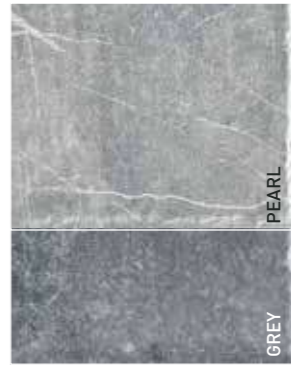

CHRONO 219



CITADEL 227



DOVER 235



LIVERMORE 243



MATERIA 255

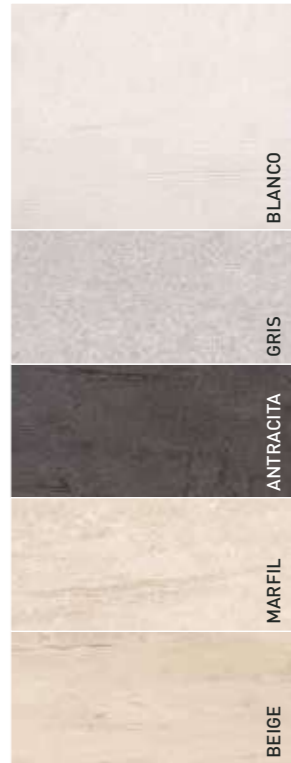

MOON 263

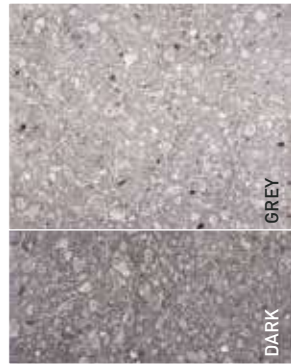



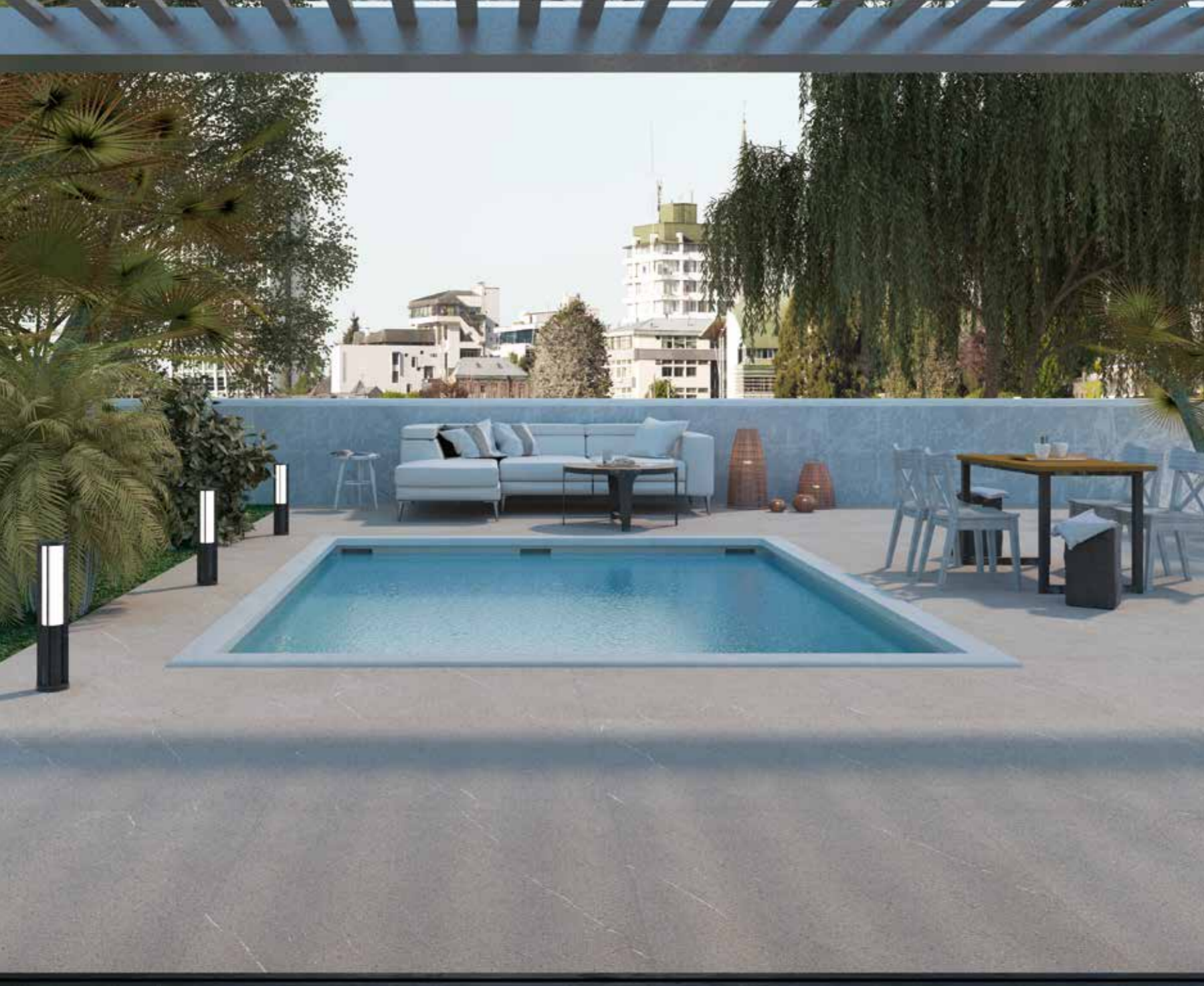

# ARU BA

PEARL

GREY

GRAPHITE

TAUPE

Dry Digital System **DDS**

**OUTDOOR**

60x60cm RC • 23,6" x 23,6"  
50x100cm RC • 23,6" x 23,6"  
100x100cm RC • 39,4" x 39,4"

**PORCELÁNICO**  
PORCELAIN TILE

**MATE**  
20MM ESPESOR  
RECTIFICADO  
MATT  
20MM THICKNESS  
RECTIFIED

→IN←OUT→Collection





	R001WD0099	ARUBA 20 PEARL RC	60x60cm	B 524
	R001WD0443	ARUBA 20 PEARL RC	50x100cm	B 645
	R001WD0091	ARUBA 20 PEARL RC	100x100cm	B 645
	R001WD0095	ARUBA 20 GREY RC	60x60cm	B 524
	R001WD0416	ARUBA 20 GREY RC	50x100cm	B 645
	R001WD0087	ARUBA 20 GREY RC	100x100cm	B 645

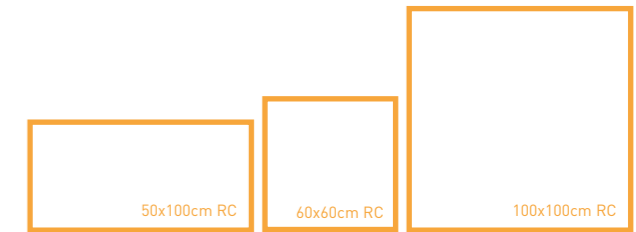

PEARL

GREY





			R001WD0097	ARUBA 20 GRAPHITE RC	60x60cm	B 524
			R001WD0418	ARUBA 20 GRAPHITE RC	50x100cm	B 645
			R001WD0089	ARUBA 20 GRAPHITE RC	100x100cm	B 645
			R001WD0093	ARUBA 20 TAUPE RC	60x60cm	B 524
			R001WD0414	ARUBA 20 TAUPE RC	50x100cm	B 645
			R001WD0085	ARUBA 20 TAUPE RC	100x100cm	B 645

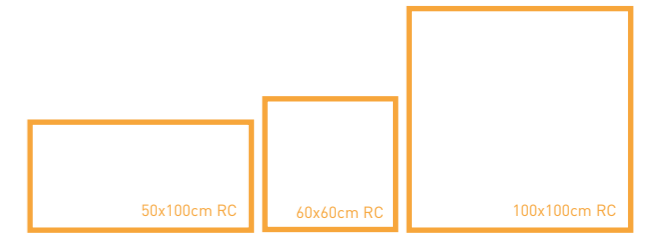

ARUBA TAUPE 50x100cm RC







ARUBA 20 GREY 100x100cm RC

→IN←OUT→Collection

Formatos IN&OUT disponibles  
 IN&OUT Sizes available

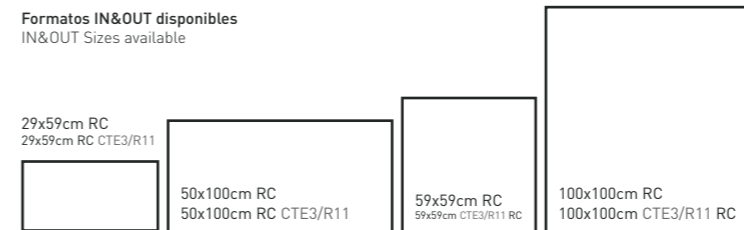

Disponible en Modular  
 Modular Available

**VARIEDAD GRÁFICA**  
**GRAPHIC VARIETY**

**ARUBA 20** GREY 100x100cm RC

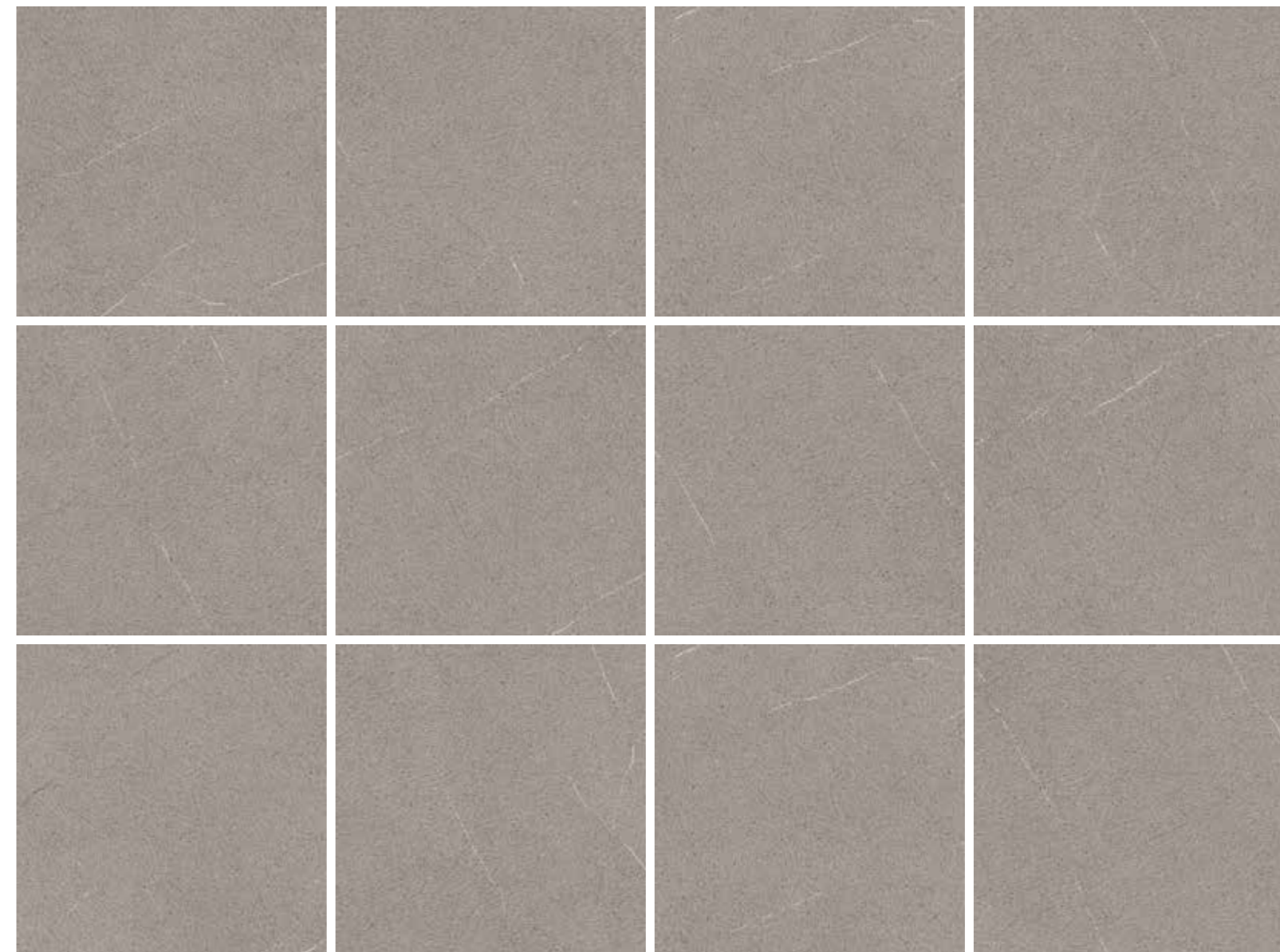

Disponible en todos los colores / Available in all colors





AXIS 20 CREAM 60x120cm RC - AXIS BLACK 60x120cm RC



AXIS 20 GREY 60x120cm RC

# AXIS

WHITE

GREY

BLACK

CREAM

## OUTDOOR

60x60cm RC • 23,6" x 23,6"  
61x61cm • 24" x 24"  
60x120cm RC • 23,6" x 47,2"

**PORCELÁNICO**  
PORCELAIN TILE

**MATE**  
20MM ESPESOR  
RECTIFICADO  
MATT  
20MM THICKNESS  
RECTIFIED



→IN←OUT→Collection



 R001W32008	AXIS 20 WHITE ANT RC	60x60cm	B 410
 R001WS6374	AXIS 20 WHITE ANT	61x61cm	B 360
 R001W32032	AXIS 20 WHITE ANT RC	60x120cm	B 600





WHITE

 R001W32012	AXIS 20 GREY ANT RC	60x60cm	B 410
 R001WS6378	AXIS 20 GREY ANT	61x61cm	B 360
 R001W32036	AXIS 20 GREY ANT RC	60x120cm	B 600



GREY





 R001W32014	AXIS 20 BLACK ANT RC	60x60cm	B 410
 R001WS6380	AXIS 20 BLACK ANT	61x61cm	B 360
 R001W32038	AXIS 20 BLACK ANT RC	60x120cm	B 600



BLACK



 R001W32010	AXIS 20 CREAM ANT RC	60x60cm	B 410
 R001WS6376	AXIS 20 CREAM ANT	61x61cm	B 360
 R001W32034	AXIS 20 CREAM ANT RC	60x120cm	B 600



CREAM







AXIS 20 WHITE 60x120cm RC · AXIS WHITE 60x120cm RC

→IN←OUT→Collection

Formatos IN&OUT disponibles  
 IN&OUT Sizes available



**VARIEDAD GRÁFICA**  
**GRAPHIC VARIETY**

AXIS 20 GREY 60x120cm RC



Disponible en todos los colores / Available in all colors





BLACKSHEEP 20 DARK 60x120cm RC



BLACKSHEEP 20 LIGHT 60x120cm RC

# BLACK SHEEP

LIGHT

DARK

**OUTDOOR**

75x75cm RC • 29,5" x 29,5"  
60x120cm RC • 23,6" x 47,2"

**PORCELÁNICO**  
PORCELAIN TILE

**MATE**  
20MM ESPESOR  
RECTIFICADO  
MATT  
20MM THICKNESS  
RECTIFIED

→IN←OUT→Collection



**BLACKSHEEP**  
LIGHT | DARK



- R001W31902 **BLACKSHEEP 20 LIGHT ANT RC** 75x75cm B 524
- R001W31794 **BLACKSHEEP 20 LIGHT ANT RC** 60x120cm B 600

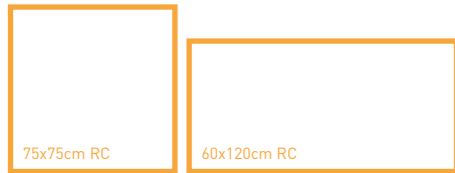

LIGHT

**BLACKSHEEP**  
LIGHT | DARK



- R001W31900 **BLACKSHEEP 20 DARK ANT RC** 75x75cm B 524
- R001W31948 **BLACKSHEEP 20 DARK ANT RC** 60x120cm B 600

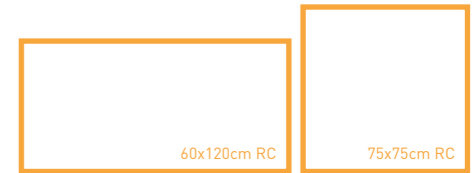

DARK





BLACKSHEEP 20 LIGHT 60x120cm RC

→IN←OUT→Collection

Formatos IN&OUT disponibles  
 IN&OUT Sizes available

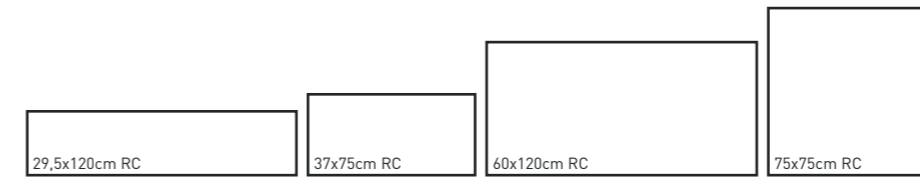

**VARIEDAD GRÁFICA**  
**GRAPHIC VARIETY**

BLACKSHEEP 20 LIGHT 60x120cm RC

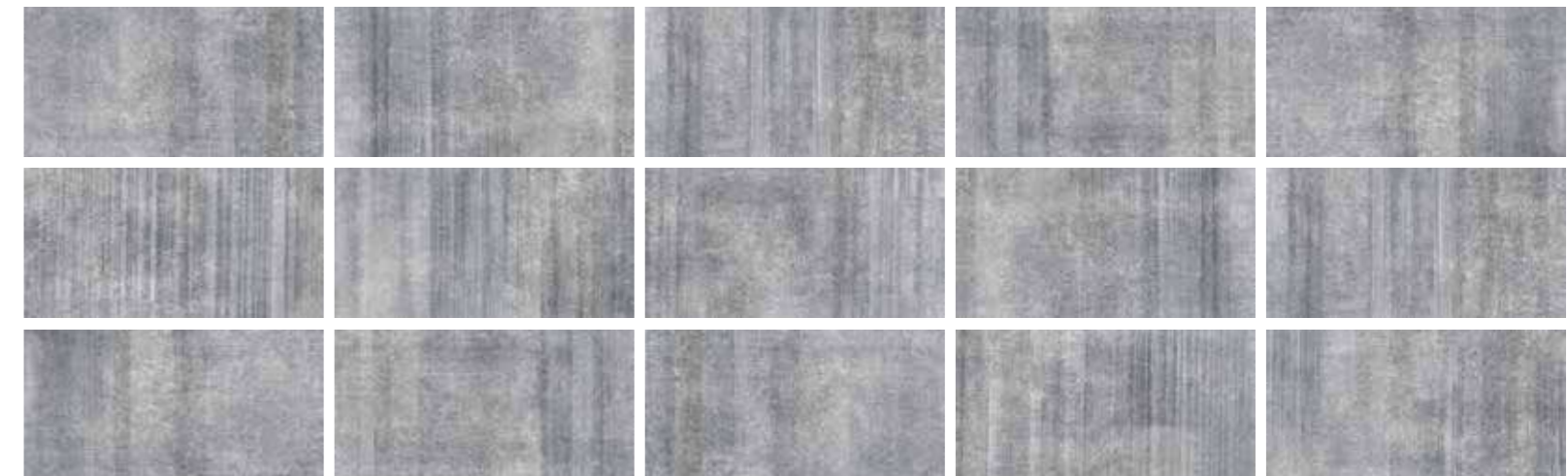

Disponible en todos los colores / Available in all colors





MÓDULAR BLUENORTE 20 GRIS 60x60cm RC



GRIS

NEGRO

# BLUE NOR TE

**OUTDOOR**

- 60x60cm RC • 23,6" x 23,6"
- 61x61cm • 24" x 24"
- 75x75cm RC • 29,5" x 29,5"
- 60x120cm RC • 23,6" x 47,2"

**PORCELÁNICO**  
PORCELAIN TILE

**MATE**  
20MM ESPESOR  
RECTIFICADO  
MATT  
20MM THICKNESS  
RECTIFIED

→IN←OUT→Collection





BLUENORTE 20 GRIS 60x60cm RC



 R001W3997	BLUENORTE 20 GRIS ANT RC	60x60cm	B 410
 R001WS4425	BLUENORTE 20 GRIS ANT	61x61cm	B 360
 R001W31112	BLUENORTE 20 GRIS ANT RC	75x75cm	B 524
 R001W31572	BLUENORTE 20 GRIS ANT RC	60x120cm	B 600



GRIS

 R001W3999	BLUENORTE 20 NEGRO ANT RC	60x60cm	B 410
 R001WS4427	BLUENORTE 20 NEGRO ANT	61x61cm	B 360
 R001W31110	BLUENORTE 20 NEGRO RC	75x75cm	B 524
 R001W31574	BLUENORTE 20 NEGRO ANT RC	60x120cm	B 600



NEGRO





→IN←OUT→Collection

Formatos IN&OUT disponibles  
IN&OUT Sizes available

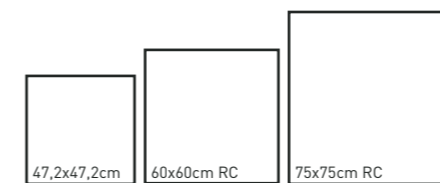

Disponible en Modular  
 Modular Available

VARIEDAD GRÁFICA  
GRAPHIC VARIETY

BLUENORTE 20 NEGRO 60x60cm RC

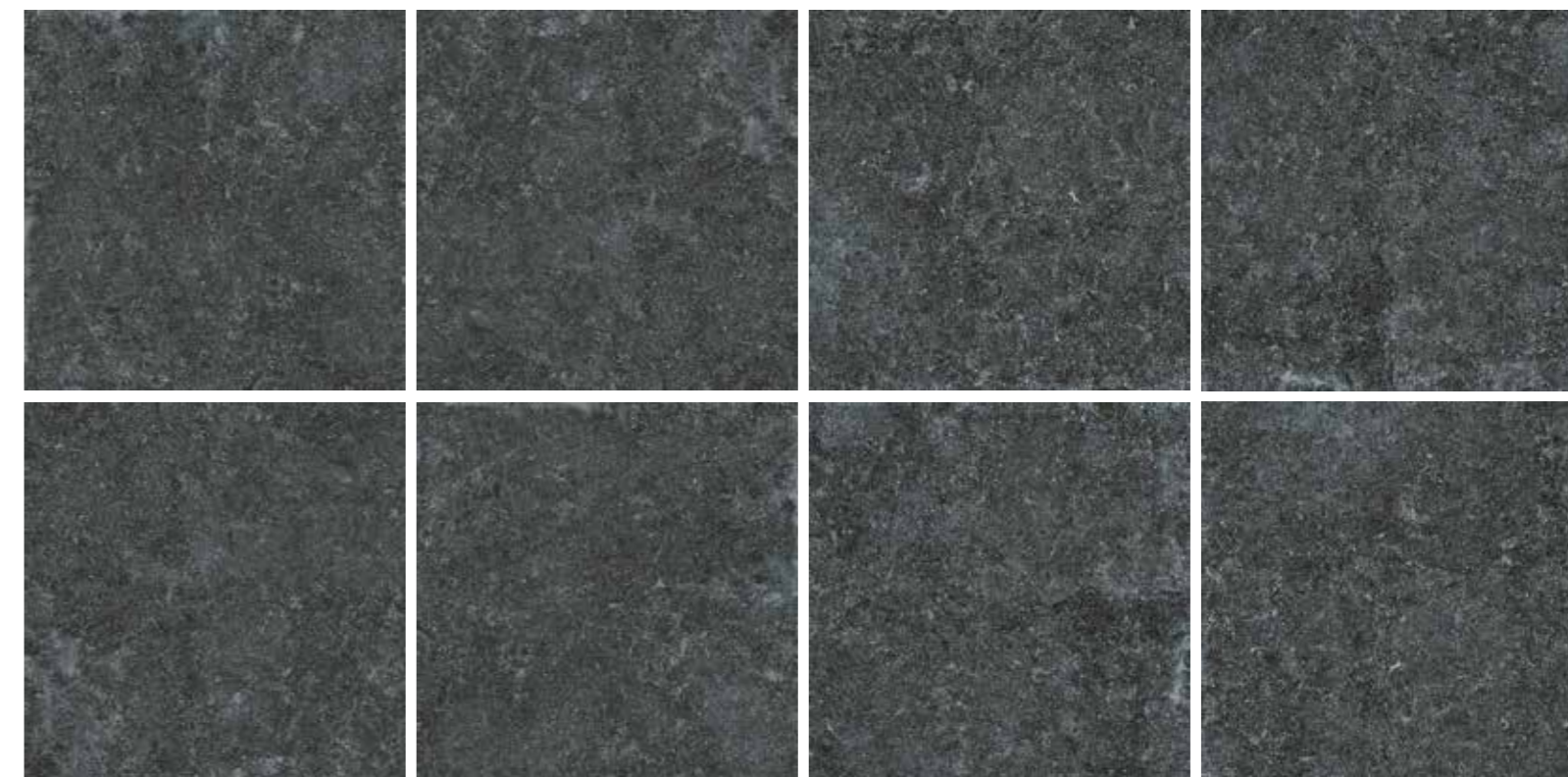

Disponible en todos los colores / Available in all colors



# BRUGES

PEARL

GREY

**OUTDOOR**

20x20cm RC • 7,9"x7,9"

**PORCELÁNICO**  
PORCELAIN TILE

**MATE**  
20MM ESPESOR  
RECTIFICADO  
MATT  
20MM THICKNESS  
RECTIFIED



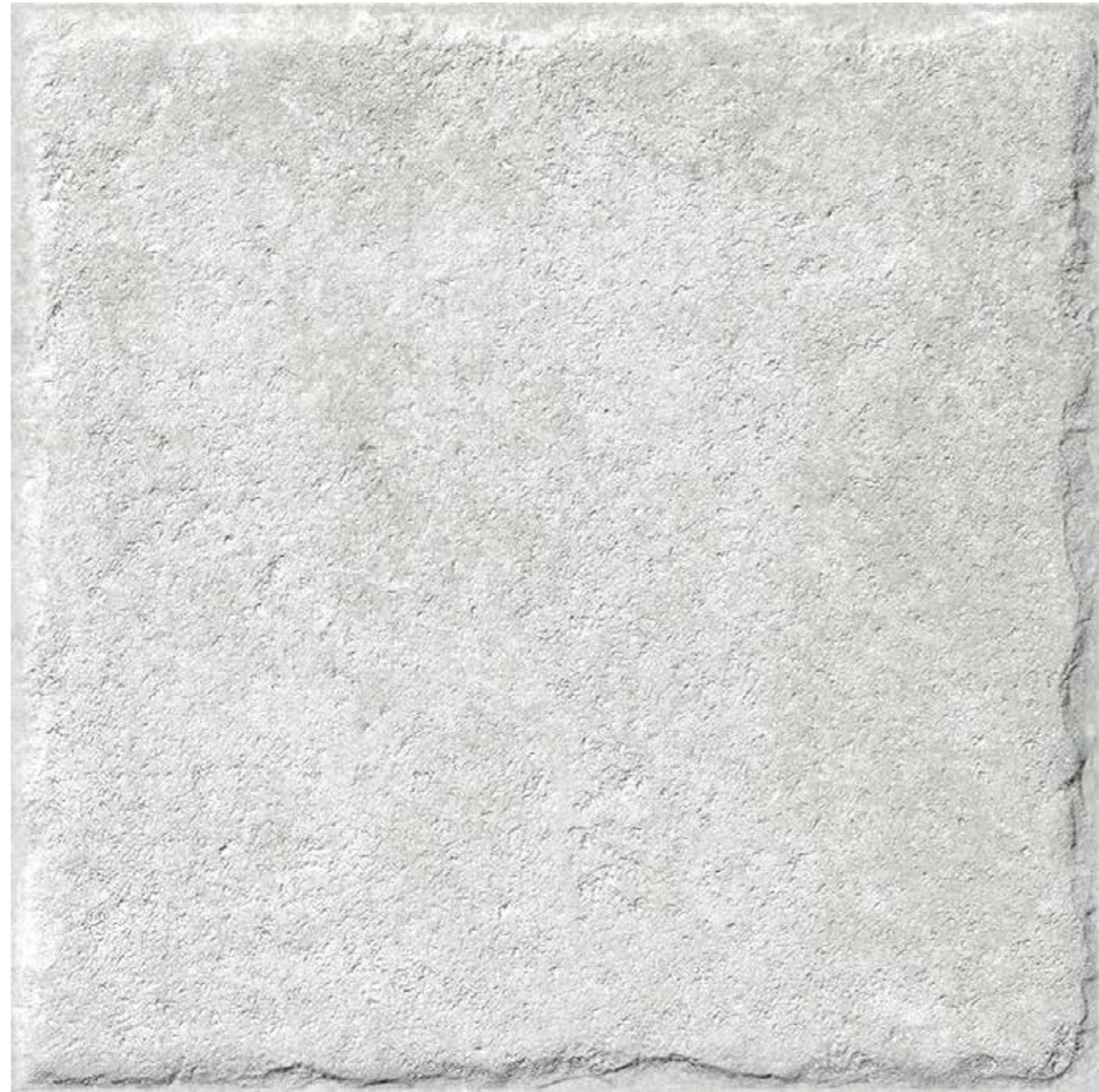

R001W32565 **BRUGES 20 PEARL** 20x20cm B600

**VARIEDAD GRÁFICA**  
*GRAPHIC VARIETY*

**BRUGES 20 PEARL** 20x20cm RC





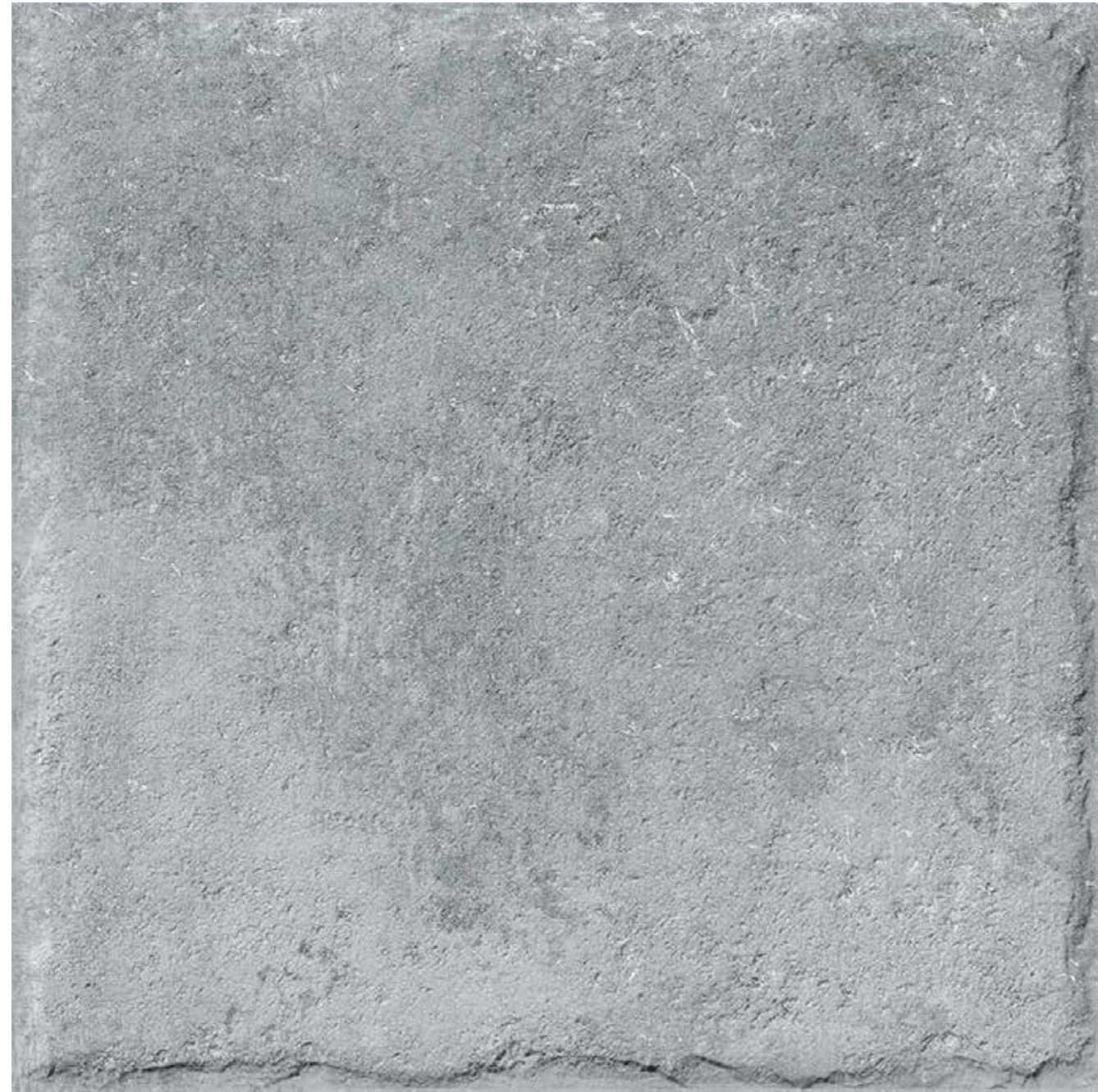

 R001W32563 **BRUGES 20 GREY** 20x20cm B600

**VARIEDAD GRÁFICA**  
*GRAPHIC VARIETY*

**BRUGES 20 GREY** 20x20cm RC







BRUGES 20 PEARL 20x20cm RC



BRUGES 20 GREY 20x20cm RC





# CHRO NO

WHITE

GREY

CREAM

**OUTDOOR**

60x60cm RC • 23,6" x 23,6"  
61x61cm • 24" x 24"  
60x120cm RC • 23,6" x 47,2"

**PORCELÁNICO**  
PORCELAIN TILE

**MATE**  
20MM ESPESOR  
RECTIFICADO  
MATT  
20MM THICKNESS  
RECTIFIED

→IN←OUT→Collection





	R001W32452	CHRONO 20 WHITE ANT RC	60x60cm	B 410
	R001WS7101	CHRONO 20 WHITE ANT	61x61cm	B 360
	R001W32421	CHRONO 20 WHITE ANT RC	60x120cm	B 600



WHITE



	R001W32450	CHRONO 20 GREY ANT RC	60x60cm	B 410
	R001WS7099	CHRONO 20 GREY ANT	61x61cm	B 360
	R001W32419	CHRONO 20 GREY ANT RC	60x120cm	B 600











GREY







  	R001W32448	<b>CHRONO 20 CREAM ANT RC</b>	60x60cm	B 410
  	R001WS7097	<b>CHRONO 20 CREAM ANT</b>	61x61cm	B 360
  	R001W32417	<b>CHRONO 20 CREAM ANT RC</b>	60x120cm	B 600

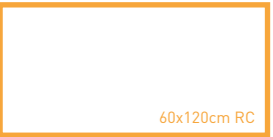

CREAM





CHRONO 20 WHITE 60x120cm RC



CHRONO  
WHITE | GREY | CREAM

PIEZAS ESPECIALES **OUT200R** PÁGINA 30  
SPECIAL PIECES **OUT200R** PAGE 30

→IN←OUT→Collection

Formatos IN&OUT disponibles  
IN&OUT Sizes available

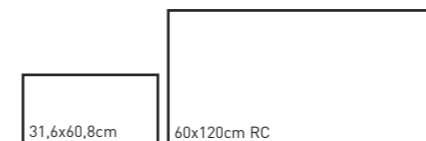

Disponible en Modular  
Modular Available

VARIEDAD GRÁFICA  
GRAPHIC VARIETY

CHRONO 20 CREAM 60x120cm RC



Disponible en todos los colores / Available in all colors



# CITA DEL

SMOKE

GREY

BLACK

## OUTDOOR







60x120cm RC • 23,6" x 47,2"  
75x75cm RC • 29,5" x 29,5"







**PORCELÁNICO**  
PORCELAIN TILE

**MATE**  
20MM ESPESOR  
RECTIFICADO  
MATT  
20MM THICKNESS  
RECTIFIED

→IN←OUT→Collection



  	R001W32181	CITADEL 20 SMOKE ANT RC	75x75cm	B 524
  	R001W32195	CITADEL 20 SMOKE ANT RC	60x120cm	B 600

  	R001W32185	CITADEL 20 GREY ANT RC	75x75cm	B 524
  	R001W32197	CITADEL 20 GREY ANT RC	60x120cm	B 600

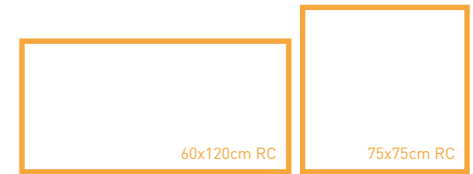
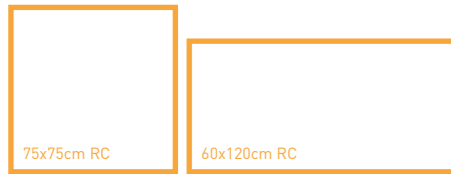

SMOKE



GREY







	R001W32183	CITADEL 20 BLACK ANT RC	75x75cm	B 524
	R001W32193	CITADEL 20 BLACK ANT RC	60x120cm	B 600

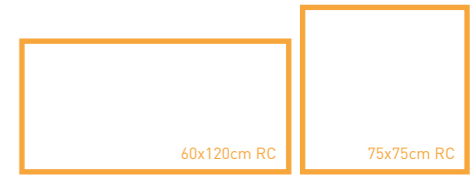





CITADEL 20 GREY 75x75cm RC

→IN←OUT→Collection

Formatos IN&OUT disponibles  
IN&OUT Sizes available

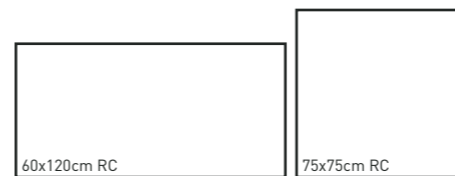

**VARIEDAD GRÁFICA**  
*GRAPHIC VARIETY*

CITADEL 20 SMOKE 75x75cm RC

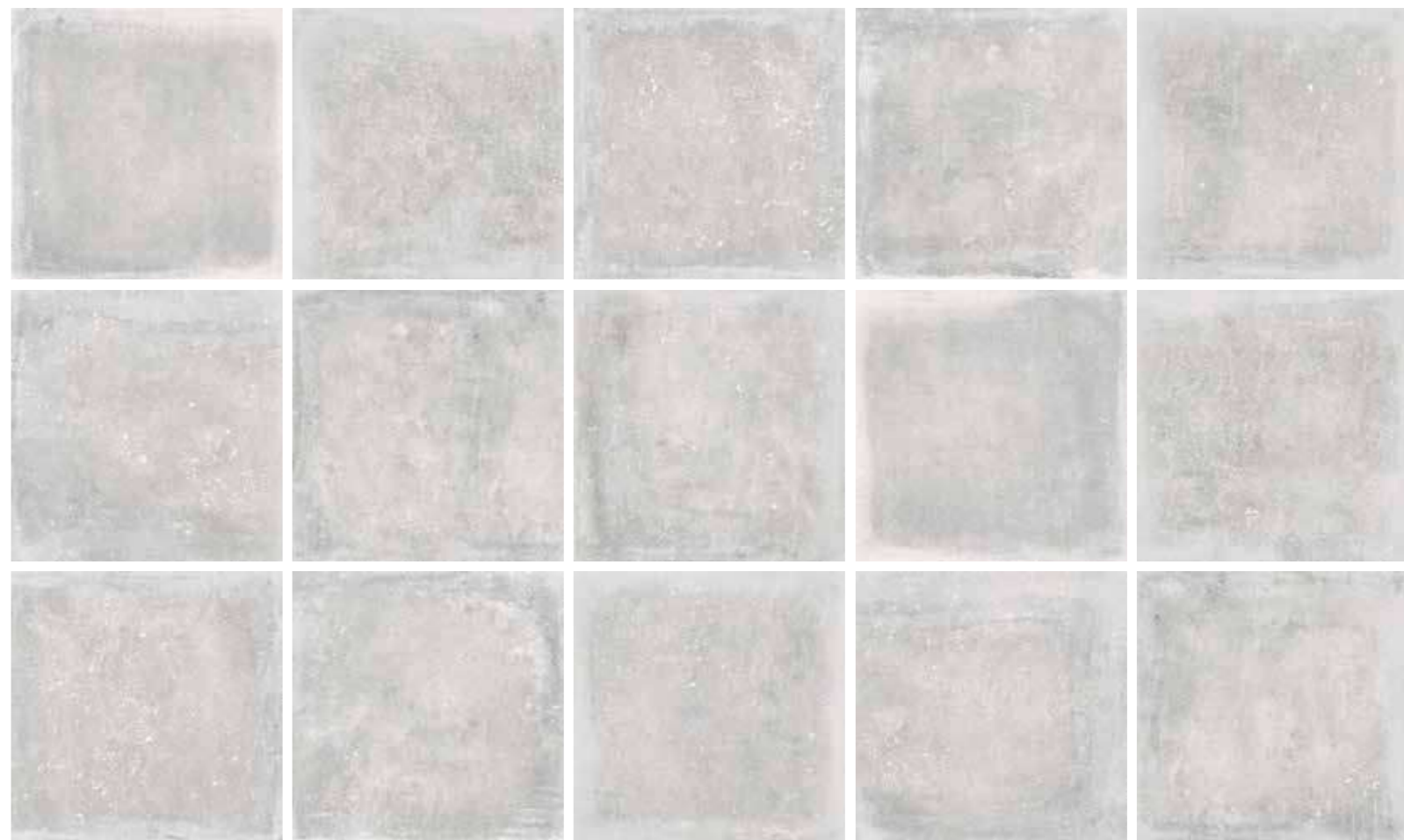

Disponible en todos los colores / Available in all colors





# DO VER

WHITE

SMOKE

GREY

CREAM

## OUTDOOR

60x120cm RC • 23,6" x 47,2"  
60x60cm RC • 23,6" x 23,6"  
61x61cm • 24" x 24"  
75x75cm RC • 29,5" x 29,5"

**PORCELÁNICO**  
PORCELAIN TILE

**MATE**  
20MM ESPESOR  
RECTIFICADO  
MATT  
20MM THICKNESS  
RECTIFIED

→IN←OUT→Collection





			R001W31868	DOVER 20 WHITE ANT RC	60x60cm	B 410
			R001WS6180	DOVER 20 WHITE ANT	61x61cm	B 360
			R001W31876	DOVER 20 WHITE ANT RC	75x75cm	B 524
			R001W31706	DOVER 20 WHITE ANT RC	60x120cm	B 600

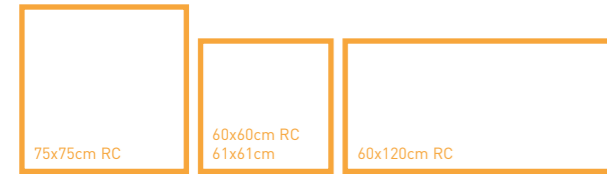

WHITE



			R001W31872	DOVER 20 SMOKE ANT RC	60x60cm	B 410
			R001WS6182	DOVER 20 SMOKE ANT	61x61cm	B 360
			R001W31880	DOVER 20 SMOKE ANT RC	75x75cm	B 524
			R001W31710	DOVER 20 SMOKE ANT RC	60x120cm	B 600

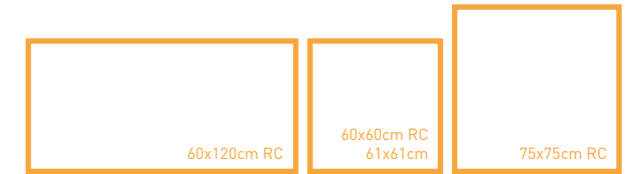

SMOKE





	R001W31874	DOVER 20 GREY ANT RC	60x60cm	B 410
	R001WS6186	DOVER 20 GREY ANT	61x61cm	B 360
	R001W31882	DOVER 20 GREY ANT RC	75x75cm	B 524
	R001W31712	DOVER 20 GREY ANT RC	60x120cm	B 600



GREY



	R001W31870	DOVER 20 CREAM ANT RC	60x60cm	B 410
	R001WS6182	DOVER 20 CREAM ANT	61x61cm	B 360
	R001W31878	DOVER 20 CREAM ANT RC	75x75cm	B 524
	R001W31708	DOVER 20 CREAM ANT RC	60x120cm	B 600

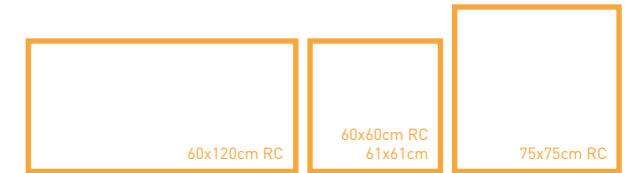

CREAM





DOVER 20 GREY 60x120cm RC - DOVER GREY 60x120cm RC



DOVER  
WHITE | SMOKE | GREY | CREAM

PIEZAS ESPECIALES OUT20OR PÁGINA 30  
SPECIAL PIECES PAGE 30

→IN←OUT→Collection

Formatos IN&OUT disponibles  
IN&OUT Sizes available

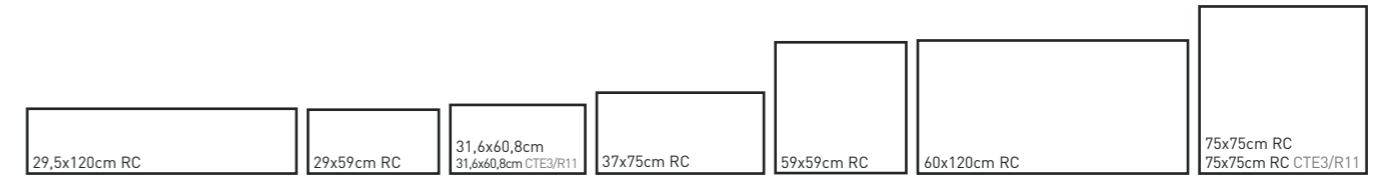

Disponibile en Modular  
Modular Available

VARIEDAD GRÁFICA  
GRAPHIC VARIETY

DOVER 20 CREAM 60x120cm RC



Disponibile en todos los colores / Available in all colors





# LIVERMORE

PEARL

GREY

BLACK

CALCITA

VISON

**OUTDOOR**

60x60cm RC • 23,6" x 23,6"  
61x61cm • 24" x 24"  
60x120cm RC • 23,6" x 47,2"

**PORCELÁNICO**  
PORCELAIN TILE

**MATE**  
20MM ESPESOR  
RECTIFICADO  
MATT  
20MM THICKNESS  
RECTIFIED

→IN←OUT→Collection





	R001WS5687	LIVERMORE 20 CALCITA ANT RC	60x60cm	B 410
	R001WS5677	LIVERMORE 20 CALCITA ANT	61x61cm	B 360
	R001WS5667	LIVERMORE 20 CALCITA ANT RC	60x120cm	B 600



CALCITA





			R001WS5689	LIVERMORE 20 VISON ANT RC	60x60cm	B 410
			R001WS5679	LIVERMORE 20 VISON ANT	61x61cm	B 360
			R001WS5669	LIVERMORE 20 VISON ANT RC	60x120cm	B 600



LIVERMORE VISON 75x75cm RC - LIVERMORE-REL VISON 60x120cm RC

VISION





	R001WS5685	LIVERMORE 20 BLACK ANT RC	60x60cm	B 410
	R001WS5675	LIVERMORE 20 BLACK ANT	61x61cm	B 360
	R001WS5665	LIVERMORE 20 BLACK ANT RC	60x120cm	B 600



BLACK



	R001WS5683	LIVERMORE 20 PEARL ANT RC	60x60cm	B 410
	R001WS5673	LIVERMORE 20 PEARL ANT	61x61cm	B 360
	R001WS5663	LIVERMORE 20 PEARL ANT RC	60x120cm	B 600



PEARL





			R001WS5681	LIVERMORE 20 GREY ANT RC	60x60cm	B 410
			R001WS5671	LIVERMORE 20 GREY ANT	61x61cm	B 360
			R001WS5661	LIVERMORE 20 GREY ANT RC	60x120cm	B 600







LIVERMORE 20 GREY 60x120cm ANT RC

→IN←OUT→Collection

Formatos IN&OUT disponibles  
 IN&OUT Sizes available

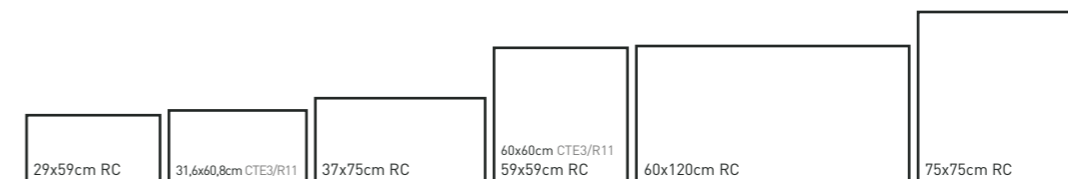

**VARIEDAD GRÁFICA**  
**GRAPHIC VARIETY**

LIVERMORE 20 PEARL 60x120cm RC

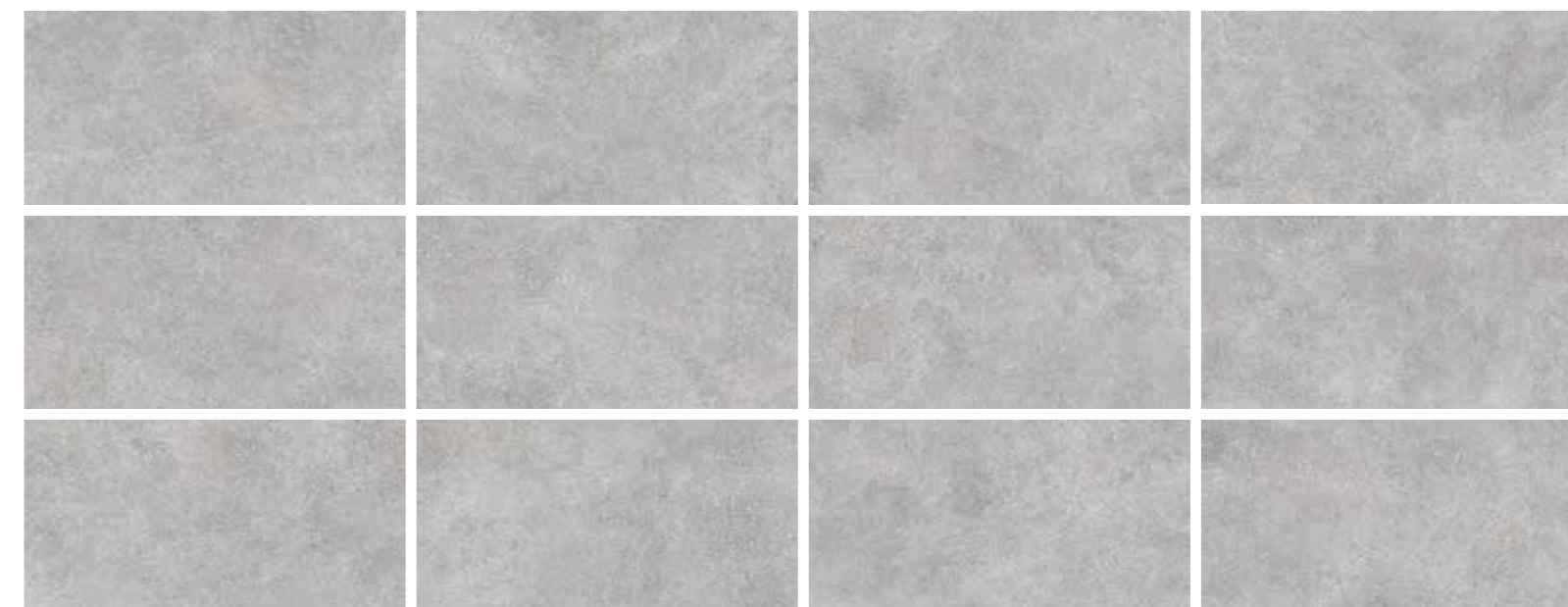

Disponible en todos los colores / Available in all colors





# MATE RIA

BLANCO

GRIS

ANTRACITA

MARFIL

BEIGE

**OUTDOOR**

60x60cm RC • 23,6" x 23,6"  
61x61cm • 24" x 24"  
75x75cm RC • 29,5" x 29,5"

**PORCELÁNICO**  
PORCELAIN TILE

**MATE**  
20MM ESPESOR  
RECTIFICADO  
MATT  
20MM THICKNESS  
RECTIFIED

→IN←OUT→Collection





			R001W31029	MATERIA 20 MARFIL ANT RC	60x60cm	B 410
			R001WS4649	MATERIA 20 MARFIL ANT	61x61cm	B 360
			R001W31082	MATERIA 20 MARFIL ANT RC	75x75cm	B 524
			R001W31033	MATERIA 20 BEIGE ANT RC	60x60cm	B 410
			R001WS4653	MATERIA 20 BEIGE ANT	61x61cm	B 360

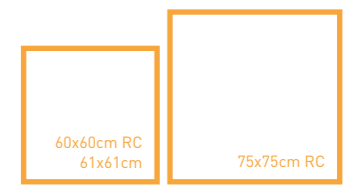

MATERIA 20 MARFIL 60x60cm RC

MARFIL

BEIGE





	R001W31031	MATERIA 20 BLANCO ANT RC	60x60cm	B 410
	R001WS4651	MATERIA 20 BLANCO ANT	61x61cm	B 360
	R001W31035	MATERIA 20 GRIS ANT RC	60x60cm	B 410
	R001WS4655	MATERIA 20 GRIS ANT	61x61cm	B 360
	R001W31084	MATERIA 20 GRIS ANT RC	75x75cm	B 524
	R001W31037	MATERIA 20 ANTRACITA ANT RC	60x60cm	B 410
	R001WS4657	MATERIA 20 ANTRACITA ANT	61x61cm	B 360
	R001W31086	MATERIA 20 ANTRACITA ANT RC	75x75cm	B 524

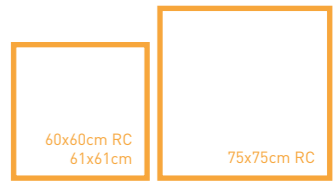

BLANCO

GRIS

ANTRACITA





MATERIA BEIGE 31,6x60,8cm · MATERIA BEIGE 60x60cm · MATERIA 20 BEIGE 60x60cm



**MS MATERIA 6X12 ESP\***  
30x30cm 5# 13,00△  
C 177



**MS MATERIA 6X6 ESP\***  
30x30cm 5# 13,00△  
C 157



**MS MATERIA 6X4 ESP\***  
30x30cm 5# 13,00△  
C 138

*\*Disponible en todos los colores  
\*Available in all colors*

**→IN←OUT→Collection**

Formatos IN&OUT disponibles  
IN&OUT Sizes available

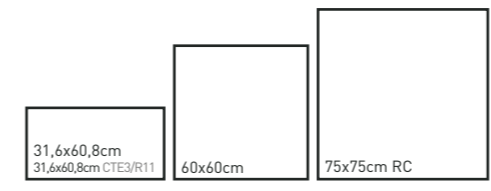

Disponible en Modular  
 Modular Available

**VARIEDAD GRÁFICA**  
*GRAPHIC VARIETY*

**MATERIA 20** GRIS 60x60cm RC



*Disponible en todos los colores / Available in all colors*



# MOON



GREY

DARK

## OUT200R

60x60cm RC • 23,6" x 23,6"  
100x100cm RC • 39,4" x 39,4"

**PORCELÁNICO**  
PORCELAIN TILE

**MATE**  
20MM ESPESOR  
RECTIFICADO  
MATT  
20MM THICKNESS  
RECTIFIED

→IN←OUT→Collection





MOON 20 GREY 100x100cm RC

			R001W32851	<b>MOON 20 GREY RC</b>	60x60cm	B 410
			R001W32859	<b>MOON 20 GREY RC</b>	100x100cm	B 600
			R001W32853	<b>MOON 20 DARK RC</b>	60x60cm	B 410
			R001W32861	<b>MOON 20 DARK RC</b>	100x100cm	B 600

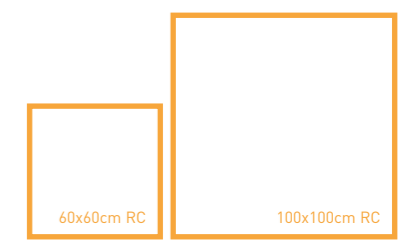

GREY



DARK





MOON 20 GREY 100x100cm RC



MOON  
WHITE | GREY | DARK

PIEZAS ESPECIALES OUT200R PÁGINA 30  
SPECIAL PIECES OUT200R PAGE 30

### →IN←OUT→Collection

Formatos IN&OUT disponibles  
IN&OUT Sizes available

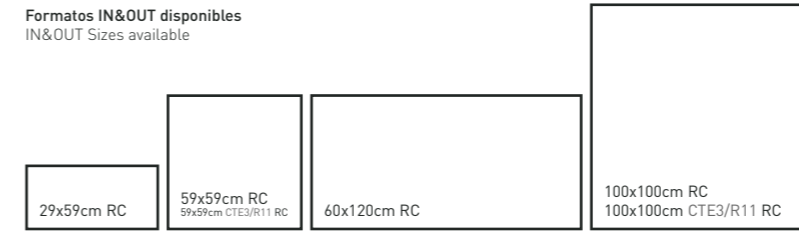

Disponible en Modular  
Modular Available

VARIEDAD GRÁFICA  
GRAPHIC VARIETY

MOON 20 GREY 100x100cm RC

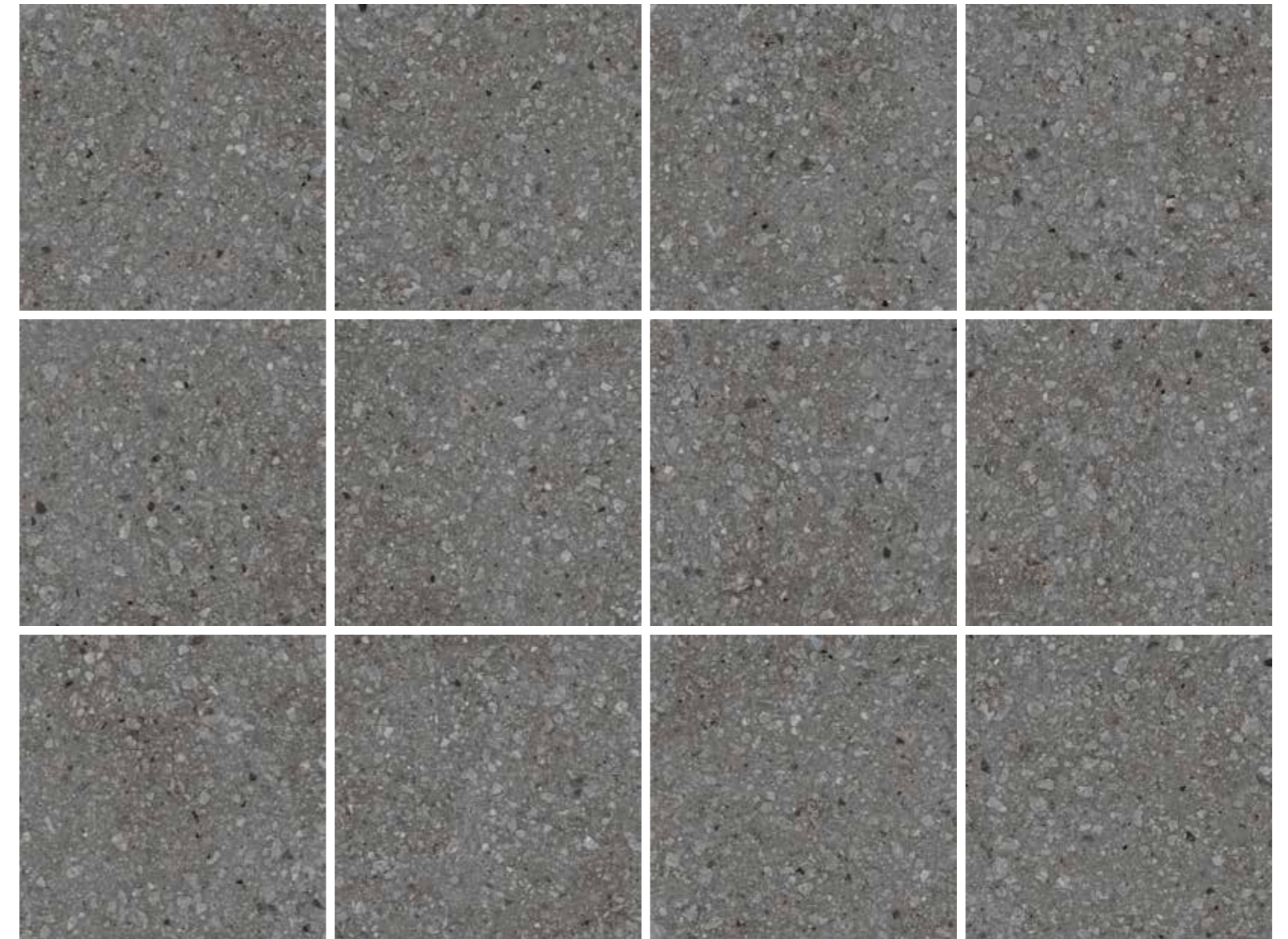

Disponible en todos los colores / Available in all colors





1. ¿QUÉ ES DDS?

3. AVANCES Y VENTAJAS

3. ACABADOS

4. APLICACIONES



1. PRELIMINARY TASKS

2. ADVANCES AND ADVANTAGES

3. FINISHES

4. APPLICATIONS



1. TÂCHES À RÉALISER AVANT LES TRAVAUX

2. AVANCÉES ET AVANTAGES

3. FINITIONS

4. APPLICATIONS



1. VOR DER VERLEGUNG

2. NEUHEITEN UND VORTEILE

3. FINISHS

4. ANWENDUNGEN



1. ¿QUÉ ES DDS?

DRY DIGITAL SYSTEM

El producto **DDS** by Rocersa es la nueva familia de producto que se presenta para cubrir aquellas necesidades técnicas que no cubren los productos esmaltados de masa coloreada que a día de hoy existen en la gama y que son mayoritarios en el mercado. **DDS** permite diseñar las piezas con la distribución de las tierras a nuestro gusto.

Consiguiendo producir modelos cerámicos con acabados naturales, simulando el trabajo de millones de años en unos pocos minutos. La piedra natural cada vez más cerca de nuestro alcance.

Es un tipo de producto mucho más cualificado, más complejo de fabricar y cuyo enfoque va destinado a profesionales que valoren estos aspectos técnicos y estéticos superiores.

3. AVANCES Y VENTAJAS

DOBLE CARGA DIGITAL

De este modo, se consigue que la pieza lleve esta mezcla superficial con el número de diseños que se precisen en cuanto a tipología y tipo de materia prima. Esta es la principal diferenciación con las antiguas tecnologías de DOBLE CARGA, donde el diseño se repetía al no poder ser DIGITAL.

CONECTIVIDAD ENTRE MÁQUINAS E INDUSTRIA 4.0

Este carro de decoración digital en seco y las máquinas de decoración inyección en húmedo tradicionales están conectadas para reforzar el diseño de tierras inicial sin taparlo. Esta posibilidad de "SINCRONIZAR" las gráficas de las dos máquinas confiere a los PRODUCTOS UNA GRAN NATURALIDAD Y PROFUNDIDAD.

4. ACABADOS

NATURAL

Cada producto se puede fabricar con la textura que más se adapta al diseño, dejando un acabado natural muy agradable al tacto y permitiendo ver los brillos de las diferentes escamas que contiene el diseño.

PULIDO

Al ser un producto doble carga, las tierras superficiales pueden pulirse sin perder el diseño.

Al utilizar tierras nobles en la parte superior se puede pulir como si de una piedra natural se tratase.

ANTIDESLIZANTE CTE3/R11

Para completar la variedad de acabados, preparamos los productos en acabado antideslizante CTE3/R11 para todos aquellos espacios que requieran una protección ante las caídas.

1. WHAT IS DDS?

DRY DIGITAL SYSTEM

**DDS**, by Rocersa, is the new product family introduced to meet those technical needs which are not covered by products glazed using coloured doughs that are currently available across the range, and which have the largest share of the market. **DDS** enables pieces to be patterned with whatever arrangement of sediment we prefer.

Managing to produce ceramic models with natural finishes, simulating the work of millions of years in a few minutes. Natural stone is coming ever closer within our reach.

It is a product type which is very well-designed, more complicated to manufacture and whose focus is aimed at professionals who value these superior technical and aesthetic aspects.

3. ADVANCES AND ADVANTAGES

DOUBLE DIGITAL LOAD

In this way, it is ensured that the piece has this mixture on the surface for the number of patterns required in terms of classification and type of raw material. This is the main difference between the old DOUBLE LOAD technologies, where patterns were repeated because they could not be DIGITIZED.

CONNECTIVITY BETWEEN MACHINES AND INDUSTRY 4.0

This digital dry decoration trolley and the traditional wet injection decoration machines are connected together to reinforce the initial sediment pattern without covering it up. Being able to "SYNCHRONIZE" the graphics of the two machines confers on the PRODUCTS A VERY DEEP AND NATURAL LOOK.

4. FINISHES

NATURAL

Each product can be manufactured with the texture that best suits the pattern, leaving a natural finish which is very pleasant to the touch and this allows you to see the brightness in the different layers of the pattern.

POLISHING

Being a product with a double load, the superficial sediment can be polished without the pattern disappearing. By using noble sediments in the upper part, it can be polished as if it were natural stone.

ANTI SLIP CTE3/R11

To complete the variety of finishes, we set up the products with a CTE3/R11 non-slip finish for all those spaces that require protection against falls.

1. QU'EST-CE QUE DDS?

DRY DIGITAL SYSTEM

Le produit **DDS** by Rocersa est la nouvelle famille de produit qui se présente pour couvrir ces besoins techniques que les produits émaillés à pâte colorée ne couvrent pas, qui existent actuellement dans la gamme et qui sont majoritaires sur le marché. **DDS** permet de concevoir les pièces avec la répartition des terres à notre goût.

En parvenant à produire des modèles céramiques aux finitions naturelles, reconstituant le travail de millions d'années en quelques minutes. La pierre naturelle est toujours plus proche de notre portée.

C'est un type de produit beaucoup plus qualifié, plus complexe à fabriquer et dont la perspective est destinée à des professionnels qui apprécient ces aspects techniques et esthétiques supérieurs.

3. AVANCÉES ET AVANTAGES

DOUBLE CHARGE NUMÉRIQUE

De cette manière, on parvient à ce que la pièce comporte ce mélange superficiel avec le nombre de conceptions nécessaires quant à la typologie et au type de matière première. C'est la principale différenciation avec les anciennes technologies à DOUBLE CHARGE, où la conception réapparaissait, ne pouvant pas être NUMÉRIQUE.

CONNECTIVITÉ ENTRE DES MACHINES ET L'INDUSTRIE 4.0

Ce charriot de décoration numérique à sec et les machines de décoration à injection à l'état humide traditionnelles sont connectés pour renforcer la conception initiale des terres sans la cacher. Cette possibilité de « SYNCHRONISER » les graphiques des deux machines confère aux PRODUITS UNE GRANDE SIMPLICITÉ ET PROFONDEUR.

4. FINITIONS

NATUREL

Chaque produit peut être fabriqué avec la texture qui s'adapte le mieux au design, laissant une finition naturelle très agréable au toucher et permettant de voir les brillances des différentes écailles comprises dans la conception.

POLISSAGE

Étant un produit à double charge, les terres superficielles peuvent se polir sans perdre la conception. En utilisant des terres nobles sur la partie supérieure, il est possible de polir comme s'il s'agissait d'une pierre naturelle.

ANTIDÉRAPANT CTE3/R11

Pour compléter la diversité des finitions, nous préparons les produits en finition antidérapante CTE3/R11 pour tous ces espaces qui ont besoin d'une protection contre les chutes.

1. WAS IST DDS?

DRY DIGITAL SYSTEM

DDS von Rocersa ist die neue Produktfamilie zur Abdeckung der technischen Anforderungen, die nicht von den glasierten Produkten mit gefärbter Füllmasse, die heute im Sortiment verfügbar sind und die Mehrheit am Markt darstellen, erfüllt werden. **DDS** ermöglicht ein Design der Teile mit beliebiger Materialverteilung.

Auf diese Weise können Keramikmodelle mit natürlichen Finishes hergestellt werden, wobei die Arbeit von Millionen Jahren in wenigen Minuten simuliert wird. Naturstein wird damit immer besser realisierbar.

Dieses sehr hochwertige und in seiner Herstellung anspruchsvolle Produkt richtet sich an Fachleute, die diese technischen Aspekte und die einzigartige Ästhetik zu schätzen wissen.

3. NEUHEITEN UND VORTEILE

DIGITAL DOUBLE CHARGE

Mit dieser Methode wird eine Oberflächenmischung mit den gewünschten Designs in Bezug auf Typologie und Materialart erreicht. Dies ist der wichtigste Unterschied zur herkömmlichen DOUBLE-CHARGE-Technologie, bei der sich das Muster wiederholte, da es nicht digital erzeugt wurde.

KONNEKTIVITÄT ZWISCHEN MASCHINEN UND INDUSTRIE 4.0

Dieser digitale Trocken-Dekorationswagen und die traditionellen Feucht-Injektionsmaschinen sind verbunden, um das ursprüngliche Erd-Design zu verstärken, ohne es zu überdecken. Die Möglichkeit, die Grafiken beider Maschinen zu „SYNCHRONISIEREN“, verleiht den PRODUKTEN EINE HERVORRAGENDE NATÜRLICHKEIT UND TIEFE.

4. FINISHS

NATÜRLICH

Jedes Produkt kann mit der am besten zum Design passenden Textur hergestellt werden. Das Finish sieht natürlich aus und fühlt sich angenehm an, während die Schimmer der verschiedenen Reliefelemente des Designs erkennbar sind.

POLIERT

Da es sich um ein Double-Charge-Produkt handelt, kann die Oberfläche poliert werden, ohne das Design zu beeinträchtigen. Durch die Verwendung edler Erden in der obersten Schicht ist das Polieren wie bei Naturstein möglich.

RUTSCHFEST CTE3/R11

Zur Vervollständigung des Sortiments an Ausführungen bieten wir die Produkte mit dem Finish CTE3/R11 für alle Bereiche an, in denen Stürze durch rutschfesten Boden verhindert werden müssen.





1. ¿QUÉ ES DDS?
3. AVANCES Y VENTAJAS
3. ACABADOS
4. APLICACIONES



1. PRELIMINARY TASKS
2. ADVANCES AND ADVANTAGES
3. FINISHES
4. APPLICATIONS



1. TÂCHES À RÉALISER AVANT LES TRAVAUX
2. AVANCÉES ET AVANTAGES
3. FINITIONS
4. APPLICATIONS



1. VOR DER VERLEGUNG
2. NEUHEITEN UND VORTEILE
3. FINISHS
4. ANWENDUNGEN



## 5. APLICACIONES

### ESPACIOS PÚBLICOS

Gracias a la doble carga, los productos **DDS** tienen una gran resistencia superficial, por lo que resiste al desgaste de alto tránsito. Cuando el pavimento sufre un desgaste más profundo, el producto no pierde diseño ya que la doble carga superior es todo masa.

Algunos de los espacios:

- Aeropuertos
- Estación de tren/Metro
- Centros comerciales
- Hospitales
- Edificios gubernamentales
- Oficinas
- Hoteles
- Negocios

### ESPACIOS URBANOS

**DDS** también cuenta con los modelos en OUTDOOR 20, 20mm de espesor, con acabado antideslizante y con una resistencia a la carga muy alta. Esto permite poder utilizar el producto:

- Plazas
- Aceras
- Rampas

### USO DOMÉSTICO

La durabilidad del producto y la variedad de diseños ofrece crear espacios en las viviendas domésticas con mucha personalidad.

### USO HIGIÉNICO

Su baja absorción de agua junto a la protección propia de los modelos, permite poder utilizarlos en espacios donde la higiene es fundamental. Esto permite poder utilizar el producto:

- Restauración
- Quirófanos
- Gimnasios/Vestuarios
- Cocinas

### MOBILIARIO

Los modelos **DDS** permiten utilizarse para realizar mobiliario que se fusiona con el entorno. Materiales con gran resistencia que permiten realizar ingletes sin roturas y de gran tamaño que permiten realizar:

- Mobiliario urbano
- Encimeras
- Lavabos
- Mesas
- Mostradores
- Muros decorativos

## 5. APPLICATIONS

### PUBLIC SPACES

Thanks to their double load, **DDS** surfaces are very resistant, so they stand up to high levels of traffic wear and tear. When slabs suffer even greater wear, the product does not lose its pattern.

Some examples:

- Airports
- Train/Metro stations
- Shopping Centres
- Hospitals
- Government buildings
- Offices
- Hotels
- Businesses

### URBAN SPACES

**DDS** also has outdoor models, the OUTDOOR 20, 20mm thick, with an anti-slip finish and highly resistant to bending. This allows the product to be used for.

Some examples:

- Squares
- Pavements
- Ramps

### DOMESTIC USE

The durability of the product and its variety of designs enables the creation of spaces in domestic homes which have a lot of character.

### POLISHING

Its low absorption of water together with the models' own protection allows us to use them in spaces where hygiene is fundamental. This allows the product to be used for.

Some examples:

- Restaurant and catering sector
- Operating theatres
- Gyms/Changing rooms
- Kitchens

### FURNITURE

DDS models can be used to make furniture that blends into the environment. Highly resistant materials which enable mitering without breaks and over large sizes allow the following to be carried out:

- Street furniture
- Worktops
- Washbasins
- Tables
- Counters
- Decorative walls

## 5. APPLICATIONS

### ESPACES PUBLICS

Grâce à la double charge, les produits DDS présentent une grande résistance superficielle, permettant de faire face à l'usure due à une forte fréquentation. Quand le revêtement subit une usure plus profonde, le produit ne perd pas de design.

Quelques exemples :

- Aéroports
- Stations de train/métro
- Centres commerciaux
- Hôpitaux
- Édifices gouvernementaux
- Bureaux
- Hôtels
- Entreprises
- Businesses

### ESPACE URBAINS

**DDS** dispose aussi des modèles en OUTDOOR 20, 20mm d'épaisseur, avec une finition antidérapante et d'une résistance à la flexion très élevée. Cela permet de pouvoir utiliser le produit.

Quelques exemples:

- Places
- Trottoirs
- Rampes

### USAGE DOMESTIQUE

La durabilité du produit et la diversité des conceptions permet de créer des espaces dans les maisons avec beaucoup de personnalité.

### USAGE HYGIÉNIQUE

Sa faible absorption d'eau avec la propre protection des modèles permet de pouvoir les utiliser dans des espaces où l'hygiène est fondamentale. Cela permet de pouvoir utiliser le produit.

Quelques exemples :

- Restauration
- Salles d'opération
- Gymnases/Vestiaires
- Cuisines

### MOBILIER

Les modèles DDS permettent d'être utilisés pour réaliser un mobilier qui fusionne avec l'environnement. Des matériaux d'une grande résistance qui permettent de réaliser des onglets sans ruptures et de grande taille:

- Mobilier urbain
- Plans de travail
- Lavabos
- Tables
- Présentoirs
- Murs décoratifs

## 5. ANWENDUNGEN

### ÖFFENTLICHE BEREICHE

Dank Double-Charge-Technologie haben DDS-Produkte eine hervorragende Oberflächenresistenz und halten dem Verschleiß durch starke Beanspruchung stand. Wenn der Bodenbelag stärker abgenutzt wird, bleibt das Design trotzdem erhalten.

Einige Beispiele:

- Flughäfen
- Bahnhöfe/U-Bahn-Haltestellen
- Einkaufszentren
- Krankenhäuser
- Regierungsgebäude
- Büros
- Hotels
- Geschäfte

### INNENSTÄDTE

DDS verfügt auch über Modelle in der Ausführung OUTDOOR 20 mit 20 mm Materialstärke, rutschfestem Finish und sehr hoher Biegefestigkeit. Dies erlaubt folgende Anwendungen.

Einige Beispiele:

- Plätze
- Gehwege
- Rampen

### HEIMISCHER GEBRAUCH

Die Widerstandsfähigkeit des Produkts und die Designvielfalt ermöglichen die Gestaltung von Räumen mit viel Charakter in Wohnbauten.

### HYGIENISCHER GEBRAUCH

Die geringe Wasserabsorption und die Schutzschicht der Modelle gestatten die Verwendung an Stellen, wo Hygiene entscheidend ist. Dies erlaubt folgende Anwendungen.

Einige Beispiele:

- Restaurants
- OP-Räume
- Fitnesscenter/Umkleieräume
- Küchen

### MÖBEL

Die DDS-Modelle können für Möbel verwendet werden, die mit der Umgebung verschmelzen. Die Materialien sind äußerst widerstandsfähig und erlauben daher die bruchfreie Herstellung großer Gehrungen z. B. für:

Einige Beispiele:

- Stadtmöbel
- Arbeitsplatten
- Waschbecken
- Tische
- Theken
- Wanddekorationen



**INFORMACIÓN TÉCNICA**  
 TECHNICAL INFORMATION  
 INFORMATION TECHNIQUE  
 TECHNISCHE INFORMATIONEN



1. EMBALAJE
2. TABLA DE ESPESORES
3. CARACTERÍSTICAS TÉCNICAS



1. PACKAGING
2. TABLE OF THICKNESSES
3. TECHNICAL CHARACTERISTICS



1. EMBALLAGE
2. TABLEAU DES ÉPAISSEURS
3. CARACTÉRISTIQUES TECHNIQUES



1. VERPACKUNG
2. TABELLE DER DICKEN
3. TECHNISCHE EIGENSCHAFTEN

	FORMATO - SIZE	ESPEJOR - THICKNESS
<b>OUTDOOR 20mm</b>	100x100 ANT RC	20mm
	50x100 ANT RC	20mm
	60x120 cm. ANT RC	20mm
	29,5x120 cm. ANT RC	20mm
	75x75 cm. ANT RC	20mm
	61x61 cm. ANT	20mm
	60x60 cm. ANT RC	20mm

FORMATO · SIZE	CAJAS - BOXES			PALET - PALLET			EUROPALET - EUROPALLET			
	Piezas/ Pieces	m <sup>2</sup>	Kg.	Cajas/ Boxes	m <sup>2</sup>	Kg.*	Cajas/ Boxes	m <sup>2</sup>	Kg.*	
<b>OUTDOOR 20mm.</b>	100x100 ANT RC	1	1,000	49	24	24,000	1180	-	-	-
	50x100 ANT RC	2	1,000	27	24	24,000	1300	-	-	-
	60x120 cm. ANT RC	1	0,720	34	-	-	-	27	19,440	930
	29,5x120 cm. ANT RC	2	0,708	35	-	-	-	32	22,656	1115
	75x75 cm. ANT RC	1	0,562	28	-	-	-	45	25,290	1240
	61x61 cm. ANT	2	0,744	34	-	-	-	30	22,320	1030
	60x60 cm. ANT RC	2	0,720	34	-	-	-	30	21,600	1015

\*Valores aproximados / Approximated values

Norma / NORM	Ensayo / TEST	ISO 13006 UNE-EN 14411	ROCERSA VALORES / VALUES
	<b>UNE-EN ISO 10545-2</b> Medida de longitud y de anchura <i>Length and width</i>	Desviación respecto del valor medio ± 0,5%	Desviación respecto del valor medio ± 0,2%
	Medida del grosor <i>Thickness</i>	Desviación respecto medida de fabricación ± 5%	Desviación respecto medida de fabricación ± 2%
	Medida de la rectitud de los lados <i>Measurement of side straightness</i>	Desviación respecto medida de fabricación ± 0,5%	Desviación respecto medida de fabricación ± 0,2%
	Medida de la ortogonalidad <i>Squareness</i>	Desviación respecto medida de fabricación ± 0,6%	Desviación respecto medida de fabricación ± 0,2%
	Medida de la planitud de la superficie <i>Surface flatness</i>	Desviación respecto medida de fabricación ± 0,5%	Desviación respecto medida de fabricación ± 0,2%
	<b>UNE-EN ISO 10545-3</b> Determinación de la absorción de agua <i>Water absorption</i>	Valor medio E ≤ 0,5%	Valor E ≤ 0,1%
	<b>UNE-EN ISO 10545-4</b> Módulos de rotura <i>Modulus of rupture</i>	Mínimo valor ≥ 35 N / mm <sup>2</sup>	Valor ≥ 40 N / mm <sup>2</sup>
	Fuerza de rotura <i>Breaking strength</i>	Espesor <i>Thickness</i> > 1.300 N	> 2.500 N
	<b>UNE-EN ISO 10545-6</b> Resistencia a la abrasión <i>Resistance to abrasion</i>	Según los valores del fabricante <i>As per manufacturer</i>	Según modelo <i>Depending on model</i>
	<b>UNE-EN ISO 10545-8</b> Determinación de la dilatación térmica lineal <i>Thermal expansion coefficient</i>	Método de ensayo disponible <i>Test method available</i>	---
	<b>UNE-EN ISO 10545-12</b> Resistencia a la helada <i>Frost resistance</i>	Exigido <i>Demanded</i>	Cumple la norma <i>Complies with the standards</i>
	<b>UNE-EN ISO 10545-13</b> Resistencia a los ácidos y bases <i>Resistance against acids and bases</i>	Según los valores del fabricante <i>As per manufacturer</i>	GLB, GHB
	Resistencia a los productos de limpieza y reactivos de piscina <i>Household detergents and additives for swimming-pools</i>	Clase/Class GB <sub>MIN</sub>	Cumple la norma <i>Complies with the standards</i>
	<b>UNE-EN ISO 10545-14</b> Resistencia a las manchas <i>Resistance to staining</i>	Clase/Class 3 <sub>MIN</sub>	Cumple la norma <i>Complies with the standards</i>



## INFORMACIÓN TÉCNICA

### TECHNICAL INFORMATION

### INFORMATION TECHNIQUE

### TECHNISCHE INFORMATIONEN



- TAREAS PREVIAS A LA OBRA
- TIPO DE COLOCACIÓN
- COLOCACIÓN
- REJUNTADO
- LIMPIEZA POSTERIOR A LA OBRA
- MANTENIMIENTO



- PRELIMINARY TASKS
- TYPE OF FIXING
- FIXING
- GROUTING
- FINAL CLEAN UP
- MAINTENANCE



- TÂCHES À RÉALISER AVANT LES TRAVAUX
- TYPE DE POSE
- POSE
- JOINTOIEMENT
- NETTOYAGE FIN DE CHANTIER
- ENTRETIEN



- VOR DER VERLEGUNG
- VERLEGUNGSTYP
- VERLEGUNG
- VERFUGUNG
- REINIGUNG NACH DER VERLEGUNG
- REINIGUNG

- TAREAS PREVIAS A LA OBRA 

## LIMPIEZA DE LA SUPERFICIE

Limpieza de la superficie

Ya sea porque queremos cambiar el material cerámico existente o porque queremos ponerlo nuevo en un lugar donde nunca lo ha habido, es necesario realizar algunos trabajos de preparación previos a la propia obra.

Una de las tareas más importantes es garantizar que la superficie en la que se colocará el nuevo material cerámico sea totalmente apta para trabajar. Para conseguir este objetivo, debemos llevar a cabo algunos trabajos de preparación para garantizar que esté totalmente limpia de polvo o cualquier otro tipo de elemento o artefacto. De esta forma, nos aseguraremos de que el material de agarre se adhiera de forma acertada a la superficie.

Las tareas de limpieza engloban los siguientes cometidos:

Limpieza de la superficie

- En el caso de que ya exista algún tipo de material cerámico instalado previamente, deberemos, de forma preliminar, romper las impurezas hasta soltarlas completamente utilizando un martillo y un cincel.
- Eliminar con las herramientas o detergentes adecuados las imperfecciones que detectemos en la superficie en la que se colocará posteriormente el material cerámico.
- Comprobar que la superficie a trabajar quede completamente lisa, sin deformaciones ni desniveles.

## COMPROBACIÓN DE LAS PIEZAS

**Comprobación del marcado de las cajas.**

Se debe comprobar que el marcado de los diferentes lotes (pallets) posea una identificación homogénea y acorde con lo que se ha pedido, verificando que no haya cajas marcadas de forma diferente.

**Comprobación del aspecto del producto.**

Se debe verificar que las características de color, brillo, diseño, textura, relieve, etc. se correspondan con el material solicitado.

**Comprobación de la homogeneidad del tono.**

Hay que comprobar que todas las cajas lleven el mismo código de tono.

**Análisis de defectos superficiales.**

Se tomará como muestra la totalidad de las piezas cerámicas de las cajas seleccionadas y, sobre cada una de ellas, se determinará la ausencia o presencia de defectos visibles que no puedan considerarse como “efectos decorativos”.

**Resistencia química.**

El objeto de esta verificación es asegurarnos de que la limpieza con un producto químico determinado no produzca un deterioro irreversible de la superficie de la baldosa cerámica, como una pérdida de brillo o decoloración.

Sobre una de las piezas, depositaremos una cantidad significativa de producto de limpieza o desincrustación que cubra una superficie significativa, y dejaremos la pieza en estas condiciones durante 24 horas. Posteriormente, lavaremos con agua abundante la superficie en la que se ha empleado el producto y comprobaremos que no presenta ninguna alteración.

- PRELIMINARY TASKS 

## CLEANING THE SURFACE

Whether we are going to replace existing tiles or it is a completely new installation, there are a few things to be done before starting work.

One of the most important tasks is preparing the surface to be tiled. This involves several preparatory processes that will guarantee the absence of dust or any other impurity or artefact. This will improve adhesion to the substrate.

Limpieza de la superficie

Preparation includes the following tasks:

- A previously tiled surface must be completely stripped of all ceramic material using a hammer and chisel.
- Remove any imperfections from the surface to be tiled with the help of suitable tools or detergents.
- Make sure that the surface is completely flat, without any irregularities.

Limpieza de la superficie

- En el caso de que ya exista algún tipo de material cerámico instalado previamente, deberemos, de forma preliminar, romper las impurezas hasta soltarlas completamente utilizando un martillo y un cincel.
- Eliminar con las herramientas o detergentes adecuados las imperfecciones que detectemos en la superficie en la que se colocará posteriormente el material cerámico.
- Comprobar que la superficie a trabajar quede completamente lisa, sin deformaciones ni desniveles.

## CHECK THE MATERIALS

**Check the markings on the boxes.**

The products from distinct pallets must be marked with a common identification, matching that ordered.

**Check product appearance.**

It must be confirmed that the product characteristics, such as colour, finish, design, texture etc. agree with what was ordered.

**Check the shade.**

All product packaging should carry matching shade codes.

**Check for surface defects.**

All tiles from selected boxes should be examined for visible defects that cannot be considered “decorative effects”.

**Chemical endurance.**

The object of this test is to determine whether cleaning the tile with a chemical product has any irreversible effect on the surface of the tile, such as dulling or discolouration.

We take one tile and apply a cleaning or descaling product to a significant area of the face. It is then left for 24 hours. Then the surface is washed with plenty of water and checked for any signs of change.

- TÂCHES À RÉALISER AVANT LES TRAVAUX 

## NETTOYAGE DE LA SURFACE

Nettoyage de la surface

Que ce soit pour remplacer un matériau céramique existant ou pour en poser là où il n’y en avait pas, quelques tâches de préparation sont nécessaires avant de commencer les travaux à proprement parler.

L’une des opérations les plus importantes est de préparer la surface qui accueillera le nouveau matériau céramique pour pouvoir travailler convenablement. Dans ce but, il faut réaliser quelques travaux de préparation pour faire en sorte qu’elle soit complètement propre et exempte de poussière, de tout autre élément ou d’appareils. Nous aurons ainsi la certitude que le matériau de liaison adhère correctement à la surface.

Les opérations de nettoyage comprennent les tâches suivantes :

- Lorsqu’il existe un matériau céramique quelconque déjà installé, il faut tout d’abord briser les impuretés en les détachant complètement à l’aide d’un marteau ou d’un burin.
- À l’aide des outils ou des produits détergents adaptés, éliminer les imperfections détectées sur la surface destinée à accueillir le matériau céramique.
- Veiller à ce que la surface de travail soit entièrement lisse, sans déformations ou dénivelés.

Limpieza de la superficie

Limpieza de la superficie

## VÉRIFICATION DES CARREAUX

**Vérification du marquage des boîtes.**

S’assurer que le marquage des différents lots (palettes) comporte une identification homogène et correspondant à la commande, et qu’il n’y a pas de boîtes marquées différemment.

**Vérification de l’aspect du produit.**

Vérifier que les caractéristiques (couleur, brillance, dessin, texture, relief, etc.) correspondent bien à celles du matériau commandé.

**Vérification de l’homogénéité du coloris.**

S’assurer que toutes les boîtes ont le même code de coloris.

**Analyse des défauts superficiels.**

Prendre comme échantillon la totalité des carreaux de céramique des boîtes sélectionnées et, pour chacun d’eux, déterminer l’absence ou la présence de défauts visibles qui ne peuvent pas être considérés comme des « effets décoratifs ».

**Résistance chimique.**

Cette vérification a pour but de s’assurer que le nettoyage réalisé avec un produit chimique en particulier n’entraîne pas une détérioration irréversible de la surface du carreau de céramique, par exemple une perte de brillance ou une décoloration.

Déposer une bonne quantité de produit de nettoyage ou désincrustant de manière à couvrir une surface significative de l’un des carreaux, puis laisser reposer dans ces conditions pendant 24 heures. Laver ensuite abondamment à l’eau la surface couverte de produit et s’assurer qu’elle ne présente aucune altération.

- VOR DER VERLEGUNG 

## REINIGUNG DER OBERFLÄCHE

Egal, ob wir das vorhandene Keramikmaterial wechseln wollen oder es neu verlegen wollen, sind einige Vorbereitungsvorgänge notwendig.

Eine der wichtigsten Aufgaben ist es, zu garantieren, dass die Oberfläche, auf die das neue Keramikmaterial verlegt wird, geeignet ist. Hierfür müssen wir einige Vorbereitungsvorgänge vornehmen, um zu garantieren, dass sie vollständig frei von Staub oder sonstigen Elementen oder Artefakten ist. So vergewissern wir uns, dass das Material korrekt auf der Oberfläche haftet.

Limpieza de la superficie

Die Reinigungsvorgänge beinhalten Folgendes:

- Falls schon ein Keramikmaterial verlegt ist, müssen wir vorerst die Unreinheiten mit einem Hammer und einem Meißel vollständig entfernen.
- Man muss die Unreinheiten mit geeigneten Werkzeugen oder Reinigungsmitteln entfernen, bevor das neue Keramikmaterial verlegt wird.
- Es muss vergewissert werden, dass die Oberfläche vollkommen glatt ist und sie keine Deformationen oder Unebenheiten vorweist.

Limpieza de la superficie

Limpieza de la superficie

Limpieza de la superficie

Limpieza de la superficie

Limpieza de la superficie

Limpieza de la superficie

### ÜBERPRÜFUNG DER STÜCKE

**Überprüfung der Markierungen der Kisten.**

Es muss überprüft werden, dass die verschiedenen Posten (Paletten) korrekt mit einer homogenen Identifizierung markiert wurden, die der Bestellung entspricht. Es muss sichergestellt werden, dass keine Kisten anders markiert sind.

**Überprüfung des Aussehens des Produktes.**

Es muss überprüft werden, dass die Farbe, der Glanz, das Design, die Textur, die Oberfläche, usw. mit dem bestellten Material übereinstimmen.

**Überprüfung der Einheitlichkeit des Farbtons.**

Es muss überprüft werden, dass alle Kisten den gleichen Code für den Farbton haben.

**Überprüfung zu Oberflächendefekte.**

Es wird ein Muster des Farbtons der Stücke aus den ausgewählten Kisten entnommen und es wird sichergestellt, dass keine sichtbaren Defekte vorhanden sind, die nicht als „dekorative Effekte“ verstanden werden können.

**Chemische Widerstandskraft.**

Das Ziel dieser Überprüfung ist es, die Reinigung mit einem bestimmten chemischen Produkt keine irreversiblen Schäden auf der Oberfläche der Keramikfliesen entstehen, wie etwa ein Glanz- oder Farbverlust.

Auf ein Stück wird eine bestimmte Menge Reinigungsmittel oder Kalkreiniger gegeben und auf der Oberfläche verteilt. Das Stück wird 24 Stunden in diesem Zustand gelassen.

Danach wird die Oberfläche mit viel Wasser abgespült und es wird überprüft, dass keine Veränderung aufgetreten ist.



## INFORMACIÓN TÉCNICA

### TECHNICAL INFORMATION

### INFORMATION TECHNIQUE

### TECHNISCHE INFORMATIONEN



1. TAREAS PREVIAS A LA OBRA
2. TIPO DE COLOCACIÓN
3. COLOCACIÓN
4. REJUNTADO
5. LIMPIEZA POSTERIOR A LA OBRA
6. MANTENIMIENTO



1. PRELIMINARY TASKS
2. TYPE OF FIXING
3. FIXING
4. GROUTING
5. FINAL CLEAN UP
6. MAINTENANCE



1. TÂCHES À RÉALISER AVANT LES TRAVAUX
2. TYPE DE POSE
3. POSE
4. JOINTOIEMENT
5. NETTOYAGE FIN DE CHANTIER
6. ENTRETIEN



1. VOR DER VERLEGUNG
2. VERLEGUNGSTYP
3. VERLEGUNG
4. VERFUGUNG
5. REINIGUNG NACH DER VERLEGUNG
6. REINIGUNG



## 2. TIPO DE COLOCACIÓN

### En seco

Según el material que se va instalar y su espesor, en este caso los modelos de la familia OUTDOOR se pueden colocar en seco, sin necesidad de mortero ni adhesivos, sobre los siguientes elementos:

- Plots
- Césped
- Gravilla
- Arena

También contamos con los modelos de la familia KERFLEX que se pueden instalar sobre:

- Chorcho
- Tela aislante

Las ventajas del tipo de colocación son las siguientes:

- No requiere colas.
- Colocación rápida, ecológica y de alto nivel estético.
- Inmediatamente transitable y fácilmente removible.

### Tradicional

Este tipo de colocación es una técnica adhesiva para pavimentación con tránsito de vehículos, lugares comerciales e industriales, rampas de acceso a garajes, etc.

Las ventajas de este tipo de colocación son las siguientes:

- Soporta las tensiones de alto tránsito.
- No absorbe manchas; se limpia fácilmente, incluso con una manguera a presión.

### Fachadas

El porcelánico es un material idóneo para instalar en fachadas debido a su baja absorción de agua. Estos son los tipos de sistema de fachadas con los que se puede instalar:

- Grapa vista.
- Grapa oculta.
- Anclaje encapsulado.
- Anclaje químico.

Las ventajas de este tipo de colocación son las siguientes:

- Aislamiento acústico.
- Aislamiento energético.
- Impermeabilidad.

## 2. TYPE OF FIXING

### DRY

Depending on the material to be installed and its thickness, in this case models from the OUTDOOR family, they can be installed dry, without any need for cement or adhesive, on the following substrates:

- Raised floors.
- Grass.
- Gravel.
- Sand.

In addition, models from the KERFLEX family can be installed on:

- Cork.
- Insulating material

The advantages of this type of fixing are:

- No adhesive required.
- Rapid fixture, ecological and aesthetically pleasing.
- Immediately traversable and easily lifted.

### Traditional

For this type of installation special ceramic cements are used which leave the tiles permanently fixed and immovable.

The advantages of this type of fixing are:

- Highly traversable (pedestrians).
- Can be grouted.

### Façades

Porcelain is the ideal material for façades due to its low water absorption. Following are the types of suitable systems for tiling façades:

- Exposed clips.
- Concealed clips.
- Encapsulated anchor.
- Chemical anchor.

The advantages of this type of fixing are:

- Acoustic insulation.
- Thermal insulation.
- Impermeability.

## 2. TYPE DE POSE

### À SEC

Sen fonction du matériau à poser et de son épaisseur, dans ce cas les modèles de la famille OUTDOOR, on peut faire une pose à sec sur les éléments suivants, sans avoir à utiliser de mortiers ou de colles :

- Plots.
- Pelouse.
- Gravier.
- Sable.

D'autre part, les modèles de la famille KERFLEX peuvent être installés sur :

- Liège.
- Toile isolante.

Voici les avantages de ce type de pose :

- Aucune colle n'est nécessaire.
- Pose rapide, écologique et très esthétique.
- Immédiatement accessible et facile à enlever.

### Traditionnelle

Pour ce type de pose, on utilise du ciment conçu spécialement pour la céramique. Une fois posés, les carreaux sont entièrement fixés et il n'est pas possible de les déplacer.

Voici les avantages de ce type de pose :

- Supporte un passage intensif (piétons).
- Permet le jointoiement du revêtement de sol ou de mur.

### Façades

Grâce à une faible absorption d'eau, le grès cérame est un matériau idéal pour les façades. Les systèmes d'installation des façades sont les suivantes :

- Agrafe apparente.
- Agrafe invisible.
- Ancrage encapsulé.
- Ancrage chimique.

Voici les avantages de ce type de pose :

- Isolation acoustique.
- Isolation thermique.
- Imperméabilité.

## 2. VERLEGUNGSTYP

### TROCKEN

Je nach dem Material und seiner Dicke, in diesem Fall die Modelle der Familie OUTDOOR, können diese ohne Mörtel oder Kleber auf folgenden Elementen trocken verlegt werden:

- Plots.
- Gras.
- Kies.
- Sand.

Wir verfügen auch über die Modelle der Familie KERFLEX, die wie folgt verlegt werden können:

- Kork.
- Isolierende Folie.

Die Vorteile dieser Verlegung sind:

- Sie bedarf keinen Kleber.
- Schnelle, ökologische und ästhetisch schöne Verlegung.
- Kann sofort begangen und einfach wieder entfernt werden.

### Traditionell

Mit dieser Verlegung werden spezielle Kleber für Keramik benutzt, wobei das Material vollkommen befestigt wird und die Stücke nicht mehr bewegt werden können.

Die Vorteile dieser Verlegung sind:

- Sie hält gut einer häufigen Begehung stand (durch Personen).
- Der Belag oder die Verkleidung können verfugt werden.

### Fassaden

Das Feinsteinzeug ist ein ideales Material, um es an Fassaden zu verlegen, da es wenig Wasser aufnimmt. Diese sind die Fassadensysteme, auf die es verlegt werden kann:

- Sichtbare Klammern.
- Unsichtbare Klammern.
- Verdeckte Verankerung.
- Chemische Verankerung.

Die Vorteile dieser Verlegung sind:

- Schalldämmung.
- Energetische Dämmung.
- Wasserundurchlässigkeit.
- Isolation thermique.
- Imperméabilité.



## INFORMACIÓN TÉCNICA

TECHNICAL INFORMATION  
INFORMATION TECHNIQUE  
TECHNISCHE INFORMATIONEN



1. TAREAS PREVIAS A LA OBRA
2. TIPO DE COLOCACIÓN
3. COLOCACIÓN
4. REJUNTADO
5. LIMPIEZA POSTERIOR A LA OBRA
6. MANTENIMIENTO



1. PRELIMINARY TASKS
2. TYPE OF FIXING
3. FIXING
4. GROUTING
5. FINAL CLEAN UP
6. MAINTENANCE



1. TÂCHES À RÉALISER AVANT LES TRAVAUX
2. TYPE DE POSE
3. POSE
4. JOINTOIEMENT
5. NETTOYAGE FIN DE CHANTIER
6. ENTRETIEN



1. VOR DER VERLEGUNG
2. VERLEGUNGSTYP
3. VERLEGUNG
4. VERFUGUNG
5. REINIGUNG NACH DER VERLEGUNG
6. REINIGUNG

### 3. COLOCACIÓN

#### ELECCIÓN DE HERRAMIENTAS

Resulta de gran importancia la correcta elección de las herramientas y útiles que nos ayudarán a llevar a cabo la colocación de nuestro material.

• Aplicador de mortero	• Marcador, soporte y plantilla
• Caja de herramientas	• Maza y aplanador
• Cortafríos y cincel	• Nivel
• Crucetas, "T" y cuñas	• Paleta
• Escuadra	• Plomada
• Espátula	• Rascador
• Flexómetro	• Maceta y martillo
• Llana, peine y talocha	• Tenazas
• Mesa de trabajo	• Ventosa

#### DISPOSICIÓN DE LAS PIEZAS

Antes de empezar a colocar cualquier pieza, hay que decidir la orientación y disposición del modelo a instalar. Presentamos algunos de los ejemplos más comunes:

Tradicional

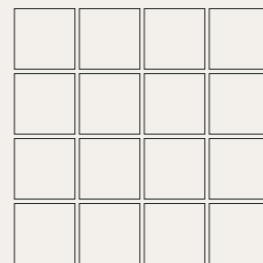

A cartabón

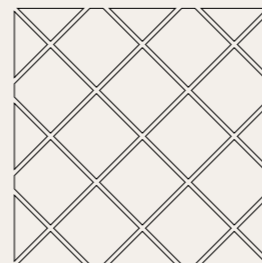

Tradicional

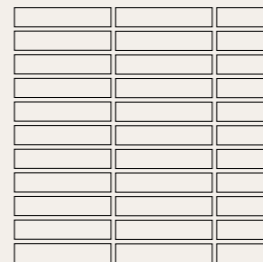

Trabado 1/3 max

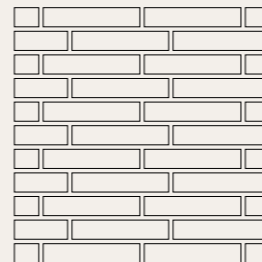

Trabado 1/3 max

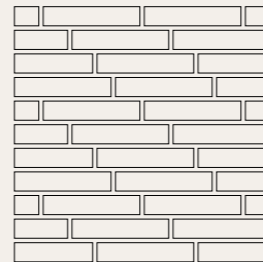

### 3. FIXING

#### CHOOSING TOOLS

Selecting the correct tools with which we are to work is of great importance.

• Trowel	• Marker, support and template
• Toolbox	• Mallet and float
• Cold chisel	• Spirit level
• Spacers and wedges	• Grouting trowel
• Set square	• Plumb line
• Spatula	• Scraper
• Measuring tape	• Mace and hammer
• Toothed trowel, comb and leveller	• Pincers
• Workbench	• Suction cup

#### TYPE OF INSTALLATION

Before starting to fix the tiles, the orientation and layout must be decided. Here we list the more common styles:

Traditional

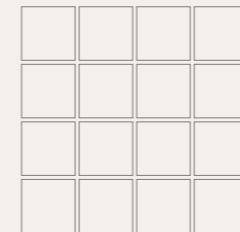

Diagonal

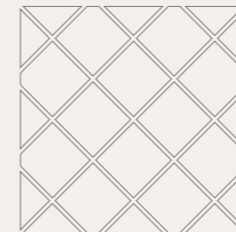

Traditional

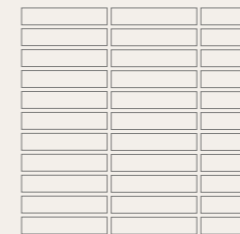

Patterned 1/3 max

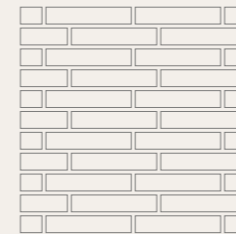

Patterned 1/3 max

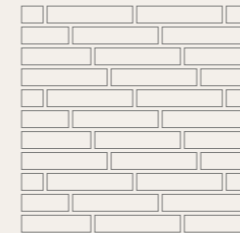

### 3. POSE

#### CHOIX DE L'OUTILLAGE

Il est extrêmement important de bien choisir le matériel et l'outillage nécessaires à la pose du matériau.

• Applicateur de mortier	• Marqueur, support et gabarit
• Boîte à outils	• Maillet et batte de carreleur
• Ciseaux à froid et burin	• Niveau
• Croisillons, profilés en T et cales	• Truelle
• Équerre	• Fil à plomb
• Spatule	• Racleur
• Mètre ruban	• Massette et marteau
• Taloché crantée, peigne et taloché	• Tenailles
• Table de travail	• Ventouse

#### DISPOSITION DES CARREAUX

Avant de commencer à poser les carreaux, il faut avant tout opter pour une orientation et une disposition du modèle à poser. Voici les exemples les plus courants :

Traditionnelle

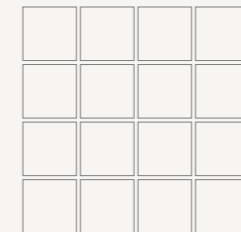

Diagonale

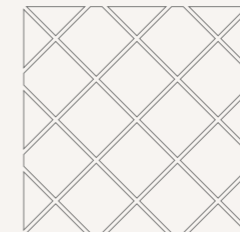

Traditionnelle

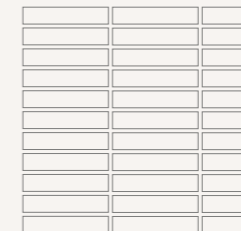

Décalée 1/3 max

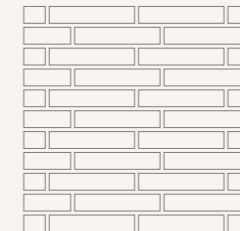

Décalée 1/3 max

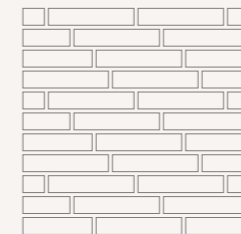

### 3. VERLEGUNG

#### AUSWAHL DER WERKZEUGE

Es ist besonders wichtig, die richtigen Werkzeuge und Hilfsmittel auszusuchen, um das Material zu verlegen.

• Mörtelanwender	• Stift, Unterlage und Schablone
• Werkzeugkoffer	• Stößel und Planierer
• Beizeisen und Meißel	• Wasserwaage
• Kreuzköpfe, „T“ und Keile	• Kelle
• Reißschmiege	• Senkblei
• Spachtel	• Schaber
• Rollmaßband	• Fäustel und Hammer
• Gezahnte Kelle, Kelle und Reibebrett	• Zangen
• Arbeitsbank	• Saugnapf

#### ANORDNUNG DER STÜCKE

Bevor die Stücke verlegt werden, muss die Orientierung und die Anordnung des Modells ausgesucht werden. Wir stellen die häufigsten Beispiele vor:

Traditionell

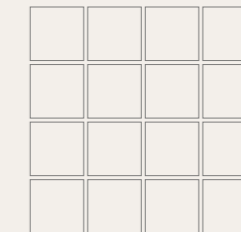

Mit Winkelmaß

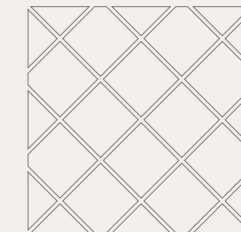

Traditionell

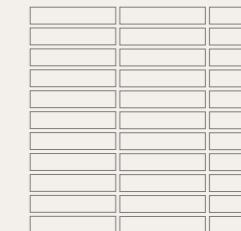

Verbunden 1/3 max

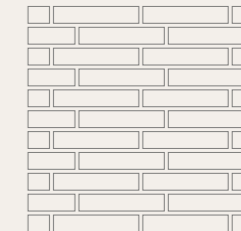

Verbunden 1/3 max

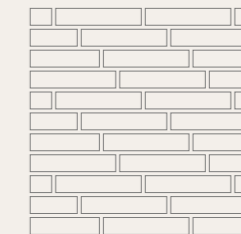



## INFORMACIÓN TÉCNICA

### TECHNICAL INFORMATION

### INFORMATION TECHNIQUE

### TECHNISCHE INFORMATIONEN



- TAREAS PREVIAS A LA OBRA
- TIPO DE COLOCACIÓN
- COLOCACIÓN
- REJUNTADO
- LIMPIEZA POSTERIOR A LA OBRA
- MANTENIMIENTO



- PRELIMINARY TASKS
- TYPE OF FIXING
- FIXING
- GROUTING
- FINAL CLEAN UP
- MAINTENANCE



- TÂCHES À RÉALISER AVANT LES TRAVAUX
- TYPE DE POSE
- POSE
- JOINTOIEMENT
- NETTOYAGE FIN DE CHANTIER
- ENTRETIEN



- VOR DER VERLEGUNG
- VERLEGUNGSTYP
- VERLEGUNG
- VERFUGUNG
- REINIGUNG NACH DER VERLEGUNG
- REINIGUNG

#### 4. REJUNTADO

#### SELECCIONAR COLOR DE REJUNTADO

A criterio de cada cliente, deberá seleccionar una pasta de rejuntado apta para cerámica del color que prefiera.

Nosotros recomendamos que sea de un tono similar al de la pieza de cerámica.

#### APLICACIÓN

Siempre despues de que el material esté instalado y seco, introducir entre las piezas de cerámica la cantidad necesaria para llenar la junta con una paleta de goma. Rapidamente con una esponja bien humedecida, retirar el sobrante. Repetir el proceso hasta cubrir todas las juntas de la pared o del pavimento.

#### 5. LIMPIEZA POSTERIOR A LA OBRA

Antes de limpiar nuestro material cerámico, será necesario que apartemos todos aquellos elementos que entorpezcan la limpieza para poder llegar a todos los rincones y eliminar por completo la suciedad. De este modo, deberemos apartar escaleras, herramientas y demás obstáculos que puedan dificultar esta tarea.

A continuación barreremos o aspiraremos el suelo de cerámica para retirar así el polvo y demás restos sólidos que pueda haber, como tornillos, grapas, crucetas, etc. Deberemos hacer hincapié en las esquinas o rincones de las estancias, ya que es donde suele acumularse este tipo de suciedad.

Seguidamente, ya se podrá empezar a fregar el piso cerámico y, para ello, se puede optar entre algún producto comercial específico para suelos de cerámica. De este modo, se deberá mezclar el limpiador comercial (siguiendo las instrucciones del envase) en el cubo de agua y limpiar toda la superficie cerámica con la fregona.

En los casos que haya pegotes de cemento o de material de rejuntado, podremos deshacernos de ellos con un estropajo suave (haremos una prueba primero sobre un trozo de pieza en la que, en el caso de que se pudiese rayar, no se vea la imperfección para asegurarnos de que podemos usar el estropajo seleccionado).

#### 6. MANTENIMIENTO

Muchos productos de limpieza de uso general que están disponibles son aceptables para el uso en nuestros productos. Se pueden emplear para la limpieza diaria detergentes o desengrasantes diluidos en agua caliente, según las indicaciones del envase del limpiador.

Es importante que el limpiador no tenga base de aceite, grasa animal o jabón. Estos componentes pueden dejar un residuo invisible al atrapar la suciedad (estratificaciones de cal de detergente o residuos de suciedad). También es importante que la baldosa reciba un enjuague a fondo con agua limpia después de que el proceso de limpieza se haya completado.

**\*\***Es muy importante tener en cuenta que el ácido fluorhídrico (HF) y derivados pueden dañar irremediablemente la baldosa.

Los pasos generales de limpieza regular para nuestros productos cerámicos se pueden resumir del siguiente modo:

- Retirar cualquier residuo sólido o líquido de la baldosa, barriendo con una escoba de cerdas suaves o pasando la aspiradora.
- Limpiar los derrames líquidos tan pronto como sea posible.

- Aplicar la cantidad y dilución del limpiador recomendadas para la baldosa (ver indicaciones del fabricante del limpiador).

Durante su uso, la limpieza de la baldosa debe hacerse de forma similar a la limpieza de cristales. Se pueden emplear productos de tipo amoniacal e incluso lejía, ambos diluidos.

#### 4. GROUTING

#### SELECTING GROUT COLOUR

A grout suitable for ceramics must be sourced in the client’s chosen colour.

We recommend a shade similar to that of the tile.

#### APPLICATION

When the tiles are installed and the cement has dried, fill the joint with paste using a rubber grouting trowel. Quickly remove any surplus with a wet sponge. Repeat the process until all joints are filled.

#### 5. FINAL CLEAN UP

Before we start cleaning, the site must be cleared of anything that could hinder access to any part. We need to be able to reach into every corner in order to clean completely. This means removing ladders, tools or any obstacle that could get in the way.

Then we sweep or vacuum the tiled floor to remove any dust or other foreign objects that there might be, such as screws, clips or spacers. Special attention must be paid to corners of the area, as this is where this type of residue tends to gather.

Now the cleaning can begin. Any preferred commercial product may be chosen if it is specifically designed for tiled floors. The commercial product must be mixed with water according to the product label. Then it is used to clean the whole area with a mop.

If we find traces of cement or grout, we can remove them using a smooth scourer. Firstly we test the scourer on a piece of tile to be certain that it does not leave scratches.

#### 6. MAINTENANCE

Many commercially available cleaning products are suitable for use with our products. Day to day cleaning can be done with detergents or degreasers diluted in hot water, following the instructions on the product label.

Products based on oil, animal fat or soap must not be used. These substances can leave an invisible residue when cleaning, such as layers of detergent or dirt. When the cleaning is complete, the tiling must be copiously rinsed with clean water.

**\*\***It is vitally important to remember that hydrofluoric acid or derivatives thereof can do irreparable damage to the tiling.

Following are the recommended steps for the regular cleaning of our products:

- Remove any solid or liquid residue from the surface using a soft broom or a vacuum cleaner.
- Clean off any liquid spillages as soon as possible.
- Dilute and apply the product according to the instructions.

Tiling should be cleaned similarly to glass surfaces. Ammonium based products and bleach can be used if diluted.

#### 4. JOINTOIEMENT

#### CHOISIR LA COULEUR DES JOINTS

Selon leurs goûts, les clients peuvent choisir la couleur souhaitée pour l’enduit de jointoiment spécial céramique.

Nous conseillons un ton semblable à celui du carreau de céramique.

#### APPLICATION

Une fois le matériau posé et sec, introduire la quantité nécessaire entre les carreaux de céramique et remplir le joint avec une truelle en caoutchouc. À l’aide d’une éponge bien humide, retirer rapidement le surplus. Répéter l’opération de façon à couvrir la totalité des joints du mur ou du sol.

#### 5. NETTOYAGE FIN DE CHANTIER

Avant de nettoyer le matériau céramique, il faut déplacer tous les éléments susceptibles de gêner le nettoyage pour pouvoir atteindre tous les recoins et éliminer entièrement la saleté. C’est pourquoi il faut ôter les échelles, les outils et tout autre obstacle qui pourrait entraver cette tâche.

Passer ensuite le balai ou l’aspirateur sur le sol en céramique pour éliminer la poussière et les autres restes solides tels que vis, agrafes, croisillons, etc. Bien insister dans les coins et les angles des pièces, c’est-à-dire là où ce type de saleté a généralement tendance à s’accumuler.

On peut ensuite commencer à passer la serpillière sur le sol, en choisissant pour cela dans le commerce un produit spécialement conçu pour les sols en céramique. Bien mélanger le produit de nettoyage dans un seau d’eau (en respectant les instructions de l’emballage), et nettoyer toute la surface en céramique à l’aide d’une serpillière.

Lorsqu’il reste des traces de ciment ou de matériau de jointoiment, on peut les éliminer en utiliser un tampon doux (pour savoir si le tampon sélectionné convient, commencer par faire un test sur un morceau de céramique peu visible, de manière à ne pas voir l’imperfection en cas de rayure).

#### 6. ENTRETIEN

Parmi les produits d’entretien général disponibles, nombreux sont ceux qui peuvent être utilisés sur nos produits. Pour le nettoyage quotidien, on peut utiliser des détergents ou des dégraissants dilués dans l’eau chaude, selon les indications de l’emballage du nettoyant.

Il est important de choisir un nettoyant qui n’est pas à base d’huile, de graisse animale ou de savon. Ces composants peuvent laisser un résidu invisible lorsqu’ils retiennent la saleté (stratifications de calcaire de détergent ou résidus de saleté). Il est important de bien rincer le carreau à l’eau propre après avoir terminé le processus de nettoyage.

**\*\***Il est important de savoir que l’acide fluorhydrique (HF) et ses dérivés peuvent abîmer le carreau de façon irréversible.

On peut résumer de la façon suivante les étapes générales de nettoyage ordinaire de nos produits en céramique :

- Retirer tout résidu solide ou liquide du carreau à l’aide d’un balai à poils souples ou d’un aspirateur.
- Nettoyer les liquides déversés aussitôt que possible.

- Respecter la quantité et la dilution du nettoyant recommandées pour le carreau (voir indications du fabricant du produit).

Pendant l’usage, effectuer le nettoyage du carreau de la même manière que le nettoyage des vitres. On peut utiliser des produits à base d’ammoniaque et même de l’eau de Javel, tous deux dilués.

#### 4. VERFUGUNG

#### VERFUGUNGSFARBE AUSSUCHEN

Der Kunde kann die Verfugungspaste für Keramik in der gewünschten Farbe auswählen. Wir empfehlen, dass diese Farbe dem Keramikstück ähnelt.

#### ANWENDUNG

Nachdem das Material verlegt und trocken ist, kann mit einer Gummispachtel die geeignete Menge Paste zwischen die Keramikstücke gepresst werden. Danach müssen die Reste sofort mit einem feuchten Schwamm entfernt werden. Der Vorgang wird wiederholt, bis alle Fugen an der Wand oder dem Belag geschlossen sind.

#### 5. REINIGUNG NACH DER VERLEGUNG

Bevor das Keramikmaterial gereinigt wird, ist es notwendig, dass wir alle Elemente, welche die Reinigung stören könnten, zu entfernen, um in alle Ecken reichen zu können, um den Schmutz vollständig entfernen zu können. So müssen also Leitern, Werkzeuge und sonstige Hindernisse entfernt werden, die die Aufgabe behindern. Danach kehren oder saugt man den Keramikboden und entfernen den Staub und andere feste Reste wie Schrauben, Klammern, Profile, usw. Es muss besonders auf die Ecken der Räume geachtet werden, da sich dort mehr Schmutz ansammelt.

Darauf kann der Keramikboden mit einem Mopp gereinigt werden, wobei ein spezifisches Produkt für Keramik ausgesucht werden kann. So wird das gewählte Reinigungsprodukt (laut den Angaben auf der Verpackung) in einem Eimer Wasser verdünnt und die gesamt Oberfläche mit dem Mopp gereinigt.

Wenn Zementreste oder Reste des Verfugungsmaterials vorhanden sind, kann man diese mit einem weichen Schwamm entfernen (zuerst an eine wenig sichtbaren Stelle probieren, ob das Stück verkratzt. So wird sichergestellt, dass der Schwamm benutzt werden kann).

#### 6. REINIGUNG

Viele verfügbare, handelsübliche Reinigungsprodukte können auf unseren Produkten benutzt werden. Für die tägliche Reinigung können Reinigungsmittel oder Fettlösmittel in warmem Wasser verdünnt werden, immer nach den Angaben auf der Verpackung.

Es ist wichtig, dass das Reinigungsmittel keine Ölbasis, Tierfettbasis oder Seifenbasis habt. Diese Mittel können unsichtbare Rückstände hinterlassen, die Schmutz aufnehmen können (Kalkrückstände der Reinigungsmittel oder Schmutz). Es ist auch wichtig, dass die Fliese nach dem Reinigungsvorgang gründlich mit Wasser abgewischt wird.

**\*\***Es ist sehr wichtig, dass Flusssäure (HF) und Derivate die Fliese unabwendbar beschädigen können.

Die allgemeinen Schritte für eine regelmäßige Reinigung unserer Keramikprodukte können wie folgt zusammengefasst werden:

- Jegliche feste oder flüssige Rückstände von der Fliese entfernen, indem mit einem weichen Besen gekehrt oder mit einem Staubsauger gereinigt wird.
- Flüssige Reste so bald wie möglich entfernen.
- Die Menge und Lösung des für Keramikfliesen empfohlenen Reinigungsmittels anwenden (sehen Sie die Herstellerangaben).

Während der Nutzung muss die Reinigung wie die Reinigung von Glas vorgenommen. Sie können Ammoniak oder Lauge benutzen, beides verdünnt.



## INFORMACIÓN EXTRA

### TECHNICAL INFORMATION

### INFORMATION TECHNIQUE

### TECHNISCHE INFORMATIONEN



1. SUELOS ANTIDESLIZANTES
2. PRODUCTOS RECTIFICADOS
3. PRODUCTOS RECOMENDADOS PARA EXTERIOR
4. CONDICIONES GENERALES DE VENTA
5. INFORMACIÓN DE UTILIDAD



1. ANTI-SLIP FLOORING
2. BUTTED TILES
3. PRODUCTS RECOMMENDED FOR OUTDOOR USE
4. GENERAL SALE TERMS
5. USEFUL INFORMATION



1. SOLS ANTIDÉRAPANTS
2. PRODUITS RECTIFIÉS
3. PRODUITS RECOMMANDÉS POUR L'EXTÉRIEUR
4. CONDITIONS GENERALES DE VENTE
5. INFORMATIONS UTILES



1. RUTSCHFESTE BÖDEN
2. MODIFIZIERTE PRODUKTE
3. FÜR AUSSEN EMPFOHLENE PRODUKTE
4. VERKAUFSBEDINGUNGEN
5. WICHTIGE INFORMATION

## 1. SUELOS ANTIDESLIZANTES

La seguridad en la utilización de los pavimentos es una de las prioridades de ROCERSA. Actualmente existen en el ámbito internacional varios sistemas para evaluar la resbaladicidad de los materiales. Los ensayos que ROCERSA aplica a sus pavimentos son los siguientes:

### RAMPA

El método de rampa inclinada, de amplia difusión en toda Europa, consiste en una plataforma regulable en inclinación sobre la que camina un técnico cualificado calzado con suela normalizada o pie descalzo. Esta rampa, que se encuentra lubricada con aceite o agua jabonosa respectivamente, incrementa progresivamente el ángulo respecto a la horizontal hasta que el técnico detecta indicios de deslizamiento. En el caso de calzado y aceite como lubricante, los pavimentos se clasifican en cinco categorías: de R9 a R13, donde el número mayor indica una fricción estática también mayor.

Clasificación	Ángulo de inclinación	Adecuado para zonas con:
R9	3° - 10°	
R10	10° - 19°	Fricción estática NORMAL
R11	19° - 27°	Fricción estática AUTOMÁTICA
R12	27° - 35°	Fricción estática ALTA
R13		FRICCIÓN ESTÁTICA MUY ALTA

### PÉNDULO

El método del péndulo de fricción, prescrito por el Código Técnico de la Edificación, consiste en un péndulo de medidas normalizadas que soporta un deslizador de caucho. La altura del equipo se ajusta para conseguir que el deslizador, que soporta una carga constante, mantenga el contacto con la superficie durante una distancia conocida. Midiendo la diferencia entre la altura inicial y la alcanzada por el péndulo después de la fricción, se asigna un valor a la superficie ensayada. Los suelos analizados con este sistema se clasifican en 4 categorías, de la 0 a la 3, donde un número mayor indica una mayor resistencia al deslizamiento.

Clasificación	Ángulo de inclinación	Adecuado para zonas con:
CTE 0	Rd ≤ 15	
CTE 1	15 > Rd ≤ 35	• Interiores con pendientes < 6%
CTE 2	35 Rd ≤ 45	• Interiores con pendientes P 6% y escaleras • Interiores húmedos (duchas, aseos, cocinas, etc.) con pendientes < 6%
CTE 3	Rd > 45	• Interiores húmedos (duchas, aseos, cocinas, etc.) con pendientes P 6% • Interiores húmedos con grasas, aceites, etc. • Exteriores y piscinas

## 1. ANTI-SLIP FLOORING

Safe usage of flooring is one of ROCERSA's priorities. There are various internationally recognised systems for evaluating a material's slip resistance. The tests that ROCERSA carries out on its products are the following:

### RAMP

The variable angle ramp method, in use all over Europe, consists of a variable angle platform on which a qualified technician walks up and down either wearing safety boots or barefoot. This ramp, which is lubricated with either oil or soapy water, is gradually inclined until the technician starts to slip. For an oil lubricated ramp and operator wearing boots, flooring is classified in five categories; R9 to R13, where a higher number indicates greater static friction.

Classification	Angle of inclination	Suitable for areas with:
R9	3° - 10°	
R10	10° - 19°	NORMAL static friction.
R11	19° - 27°	AUTOMATIC static friction.
R12	27° - 35°	HIGH static friction
R13		VERY HIGH STATIC FRICTION

### PENDULUM

The pendulum slip resistance test, required by the Spanish technical building code, consists of a standardised pendulum supporting a rubber slider. Height is adjusted so that the slider, with a constant load, remains in contact with the surface for a set distance. According to the difference between the starting height and that reached by the pendulum after the friction, the flooring is graded with a value. Surfaces analysed with this method are classified as 0 to 3, where a higher number means greater slip resistance.

Classification	Angle of inclination	Suitable for areas with:
CTE 0	Rd ≤ 15	
CTE 1	15 > Rd ≤ 35	• Interiors with incline < 6 %
CTE 2	35 Rd ≤ 45	• Interiors with incline P 6 % and stairs • Interiors with moisture (showers, bathrooms, kitchens etc.) with incline < 6 %
CTE 3	Rd > 45	• Interiors with moisture (showers, bathrooms, kitchens etc.) with incline P 6 % • Interiors with grease or oil etc. • Exteriors and pools

## 1. SOLS ANTIDÉRAPANTS

La sécurité d'utilisation des revêtements de sol est l'une des priorités de ROCERSA. À l'heure actuelle, il existe plusieurs systèmes au niveau international pour évaluer la glissance des matériaux. Voici les tests réalisés par ROCERSA sur ses revêtements de sol :

### RAMPE

La méthode de la rampe inclinée, très courante dans toute l'Europe, est réalisée sur une plateforme à inclinaison réglable sur laquelle marche un technicien qualifié, avec des chaussures normalisées ou pieds nus. On augmente progressivement l'angle d'inclinaison de cette rampe, lubrifiée avec de l'huile ou de l'eau savonneuse respectivement, jusqu'à ce que le technicien détecte des signes de glissement. Dans le cas des chaussures et de la lubrification à l'huile, les revêtements de sol sont classés en cinq catégories : de R9 à R13, sachant que plus le chiffre est élevé, plus le frottement statique est important.

Classification	Angle d'inclinaison	Adapté aux zones avec :
R9	3° - 10°	
R10	10° - 19°	Frottement statique NORMAL
R11	19° - 27°	Frottement statique AUTOMATIQUE
R12	27° - 35°	Frottement statique ÉLEVÉ
R13		FROTTEMENT STATIQUE TRÈS ÉLEVÉ

### PENDULE

La méthode du pendule de frottement, prescrite par le Code technique espagnol de la construction, est réalisée avec un pendule aux dimensions normalisées qui soutient un patin en caoutchouc. La hauteur de l'appareil est réglée de façon à ce que le patin, qui supporte une charge constante, reste en contact avec la surface pendant une distance déterminée. En mesurant la différence entre la hauteur de départ et celle atteinte par le pendule après le frottement, on attribue une valeur à la surface testée. Les sols testés avec ce système sont classés en 4 catégories, de 0 à 3 ; plus le chiffre est élevé, plus la résistance au glissement est grande.

Classification	Angle d'inclinaison	Adapté aux zones avec :
CTE 0	Rd ≤ 15	
CTE 1	15 > Rd ≤ 35	• Intérieurs avec pentes < 6 %
CTE 2	35 Rd ≤ 45	• Intérieurs avec pentes P 6 % et escaliers • Intérieurs humides (douches, toilettes, cuisines, etc.) avec pentes < 6 %
CTE 3	Rd > 45	• Intérieurs humides (douches, toilettes, cuisines, etc.) avec pentes P 6 % • Intérieurs humides avec graisses, huiles, etc. • Extérieurs et piscines

## 1. RUTSCHFESTE BÖDEN

Die Benutzungssicherheit der Beläge ist eine der Prioritäten bei ROCERSA. Aktuell gibt es auf internationaler Ebene einige Systeme, um die Rutschfestigkeit der Materialien zu überprüfen. ROCERSA wendet folgende Proben an:

### RAMPE

Die Methode der geneigten Rampe ist in Europa weit verbreitet und besteht aus einer in Neigung einstellbaren Plattform, über die ein qualifizierter Techniker mit einer normalisierten Sole oder barfuß läuft. Die Rampe ist jeweils mit Öl oder Seifenwasser geschmiert und wird immer stärker gegenüber der Waagerechten geneigt, bis der Techniker Anzeichen merkt, dass er gleitet. Im Falle von der Kombination Schuhe und Öl als Schmiermittel werden die Beläge in fünf Kategorien eingestuft, R9 bis R13, wobei die größere Zahl eine höhere Haftreibung angibt.

Einteilung	Neigungswinkel	Geeignet für Bereiche mit:
R9	3° - 10°	
R10	10° - 19°	NORMALER Haftreibung
R11	19° - 27°	AUTOMATISCHE Haftreibung
R12	27° - 35°	HOHE Haftreibung
R13		SEHR HOHE HAFTREIBUNG

### PENDEL

Die Methode des Pendelgeräts, die von der spanischen Bauordnung vorgeschrieben wird, besteht aus einem Pendel mit normalisierten Maßen mit Gummigleitrollen. Die Höhe der Anlage wird so eingestellt, dass die Gleitrollen, die ein konstantes Gewicht aushalten, über eine bekannte Distanz immer mit der Oberfläche im Kontakt stehen. Es wird die Differenz zwischen der anfänglichen Höhe und die des Pendels nach der Reibung gemessen und die geprüfte Oberfläche bekommt so einen Wert. Die mit diesem System überprüften Böden werden in 4 Kategorien, von 0 bis 3, eingestuft, wobei die höhere Zahl eine höhere Rutschfestigkeit angibt.

Einteilung	Neigungswinkel	Geeignet für Bereiche mit:
CTE 0	Rd ≤ 15	
CTE 1	15 > Rd ≤ 35	• Innenräume mit Neigungen < 6 %
CTE 2	35 Rd ≤ 45	• Innenräume mit Neigungen P 6 % und Treppen • Feuchte Innenräume (Bäder, Toiletten, Küchen, usw.) mit Neigungen < 6 %.
CTE 3	Rd > 45	• Feuchte Innenräume (Bäder, Toiletten, Küchen, usw.) mit Neigungen P 6 %. • Feuchte Innenräume mit Fetten, Ölen, usw. • Außenbereiche und Schwimmbäder



## INFORMACIÓN EXTRA

### TECHNICAL INFORMATION

### INFORMATION TECHNIQUE

### TECHNISCHE INFORMATIONEN



#### 1. SUELOS ANTIDESLIZANTES

#### 2. PRODUCTOS RECTIFICADOS

#### 3. PRODUCTOS RECOMENDADOS PARA EXTERIOR

#### 4. CONDICIONES GENERALES DE VENTA

#### 5. INFORMACIÓN DE UTILIDAD



#### ANTI-SLIP FLOORING

#### 2. BUTTED TILES

#### 3. PRODUCTS RECOMMENDED FOR OUTDOOR USE

#### 4. GENERAL SALE TERMS

#### 5. USEFUL INFORMATION



#### 1. SOLS ANTIDÉRAPANTS

#### 2. PRODUITS RECTIFIÉS

#### 3. PRODUITS RECOMMANDÉS POUR L'EXTÉRIEUR

#### 4. CONDITIONS GENERALES DE VENTE

#### 5. INFORMATIONS UTILES



#### 1. RUTSCHFESTE BÖDEN

#### 2. MODIFIZIERTE PRODUKTE

#### 3. FÜR AUSSEN EMPFOHLENE PRODUKTE

#### 4. VERKAUFSBEDINGUNGEN

#### 5. WICHTIGE INFORMATION

## PIE DESCALZO

En el caso del metodo del pie desnudo y agua jabonosa la clasificación se reduce a tres gradaciones, A, B y C en la que la primera corresponde a ángulos de rampa mayores o iguales a 12º y la clase C a ángulos mayores o iguales a 24º.

Clasificación	Ángulo de inclinación	Adecuado para zonas con:
Clase A	≤ 12°	<ul style="list-style-type: none"><li>Zonas de paso de andar descalzo.</li><li>Vestuarios individuales y comunes.</li><li>Suelos de piscinas en zonas que no son de natación si la profundidad del agua &gt; de 80 cm.</li></ul>
Clase B	≤ 18°	<ul style="list-style-type: none"><li>Zonas de paso de andar descalzo no clasificadas en el grupo A.</li><li>Zonas de instalación de pulverización desinfectante.</li><li>Suelos de piscinas en las zonas que no son de natación, si la profundidad es &gt; de 80 cm.</li><li>Secciones que no son de natación en piscinas de oleaje.</li><li>Suelos móviles.</li><li>Piscinas infantiles.</li><li>Escaleras que se meten en el agua.</li><li>Escaleras que se meten en el agua a una profundidad máxima de 1 metro con barandillas a ambos lados.</li><li>Escaleras fuera de la zona de baño.</li></ul>
Clase C	≤ 24°	<ul style="list-style-type: none"><li>Escaleras que se meten en el agua no clasificadas en la clase B.</li><li>Piscinas que se atraviesan nadando.</li><li>Diseño de bordes de piscina inclinados.</li></ul>

Cabe señalar que, al aumentar la rugosidad de la superficie, tiende a mejorar la fricción, pero, al mismo tiempo, aumenta la tendencia a la suciedad. Por otra parte, el uso de relieves superficiales antideslizantes puede provocar ligeras molestias al caminar sobre ellos, por lo que esta solución suele utilizarse en aquellas aplicaciones en las que resulta prioritaria la seguridad frente al resto de condicionantes (uso industrial, aceras exteriores, etc.).

## BAREFOOT

The test with barefoot operator and soapy water produces one of three grades, A, B or C, where A corresponds to a ramp angle of no less than 12° and C to no less than 24°.

Classification	Angle of inclination	Suitable for areas with:
Class A	≤ 12°	<ul style="list-style-type: none"><li>Barefoot pedestrian areas.</li><li>Individual and shared changing rooms.</li><li>Pool floor in areas not for swimming where the depth of water is &gt; 80 cm.</li></ul>
Class B	≤ 18°	<ul style="list-style-type: none"><li>Barefoot pedestrian areas not in group A.</li><li>Areas where disinfectant is sprayed.</li><li>Pool floor in areas not for swimming where the depth &gt; 80 cm.</li><li>Areas not for swimming in pools with wave machines.</li><li>Movable floors.</li><li>Children's pools.</li><li>Pool ladders.</li><li>Pool ladders in water no greater than 1 metre deep and with handrails both sides.</li><li>Stairs away from the bathing area.</li></ul>
Class C	≤ 24°	<ul style="list-style-type: none"><li>Pool ladders not in class B.</li><li>Pools that have to be swum across.</li><li>Design of inclined pool borders.</li></ul>

It must be pointed out that although a rougher surface will increase friction, it will also tend to get dirtier. The use of anti-slip surface textures can be uncomfortable to walk on, so this solution is usually applied to situations where safety is the major factor (industrial, exterior footpaths etc.).

## PIEDS NUS

Dans le cas de la méthode avec pieds nus et eau savonneuse, la classification se réduit à trois niveaux, A, B et C ; la première correspond aux angles de rampe supérieurs ou égaux à 12 ° et la classe C aux angles supérieurs ou égaux à 24 °.

Classification	Angle d'inclinaison	Adapté aux zones avec
Classe A	≤ 12°	<ul style="list-style-type: none"><li>Zones de passage pieds nus.</li><li>Vestiaires individuels et collectifs.</li><li>Sols des piscines dans les zones non destinées à la natation, si la profondeur de l'eau est &gt; à 80 cm.</li></ul>
Classe B	≤ 18°	<ul style="list-style-type: none"><li>Zones de passage pieds nus non classées dans le groupe A.</li><li>Zones d'installation de pulvérisation de désinfectant.</li><li>Sols des piscines dans les zones non destinées à la natation, si la profondeur est &gt; à 80 cm.</li><li>Sections non destinées à la natation dans les piscines à vagues.</li><li>Sols mobiles.</li><li>Piscines pour enfants.</li><li>Escaliers dans l'eau.</li><li>Escaliers dans l'eau à une profondeur maximale de 1 mètre, avec des rambarde des deux côtés.</li><li>Escaliers hors de la zone de baignade.</li></ul>
Classe C	≤ 24°	<ul style="list-style-type: none"><li>Escaliers dans l'eau non classés dans la catégorie B.</li><li>Piscines à traverser à la nage.</li><li>Conception de bords de piscines inclinés.</li></ul>

Il faut signaler que plus la rugosité de la surface est élevée, plus le frottement a tendance à s'améliorer, mais plus la surface est salissante. D'autre part, l'utilisation de reliefs antidérapants sur la surface peut éventuellement gêner lorsque l'on marche dessus. Cette solution est par conséquent utilisée dans les cas où l'on donne la priorité à la sécurité par rapport aux autres facteurs (usage industriel, trottoirs extérieurs, etc.).

## BARFUSS

Bei der Barfußmethode und Seifenwasser gibt es drei Einstufungen, A, B und C, wobei die Erste den Neigungswinkeln größer oder gleich wie 12 ° entspricht und die Klasse C Neigungswinkel größer oder gleich wie 24 ° entspricht.

Einteilung	Neigungswinkel	Geeignet für Bereiche mit:
KLASSE A	≤ 12°	<ul style="list-style-type: none"><li>Bereiche, in denen barfuß gelaufen wird.</li><li>Einzel- und Gemeinschaftsumkleidekabinen.</li><li>Schwimmbadböden in Bereichen, die nicht zum schwimmen geeignet sind, wenn die Wassertiefe &gt; als 80 cm beträgt.</li></ul>
KLASSE B	≤ 18°	<ul style="list-style-type: none"><li>Bereiche, in denen barfuß gelaufen wird, die nicht in der Klasse A eingestuft sind</li><li>Bereichen in denen Desinfektionsmittel zerstäubt wird.</li><li>Schwimmbadböden in Bereichen, die nicht zum schwimmen geeignet sind, wenn die Wassertiefe &gt; als 80 cm beträgt.</li><li>Bereiche in Wellenbädern, die nicht zum schwimmen geeignet sind.</li><li>Bewegliche Böden.</li><li>Kinderschwimmbecken.</li><li>Stufen unter Wasser.</li><li>Stufen unter Wasser mit einer maximalen Tiefe von 1 Meter mit Geländer auf beiden Seiten.</li><li>Treppen außerhalb der Badebereichs.</li></ul>
KLASSE C	≤ 24°	<ul style="list-style-type: none"><li>Stufen, die in das Wasser reichen, aber nicht in Klasse B eingestuft werden.</li><li>Schwimmbäder, die durchgeschwommen werden.</li><li>Geneigte Schwimmbadränder.</li></ul>

Wir weisen darauf hin, dass bei höherer Rauheit die Oberfläche besser haftet, dabei aber auch mehr Schmutz ansammelt. Andererseits kann die raue Oberfläche leicht stören, wenn man über sie läuft, diese Lösung wird normalerweise bei Anwendungen benutzt, bei denen die Sicherheit Vorrang über die restlichen Elemente hat (Gewerbe, Gehwege, usw.).



## INFORMACIÓN EXTRA

### TECHNICAL INFORMATION

### INFORMATION TECHNIQUE

### TECHNISCHE INFORMATIONEN



#### 1. SUELOS ANTIDESLIZANTES

#### 2. PRODUCTOS RECTIFICADOS

#### 3. PRODUCTOS RECOMENDADOS PARA EXTERIOR

#### 4. CONDICIONES GENERALES DE VENTA

#### 5. INFORMACIÓN DE UTILIDAD



- ANTI-SLIP FLOORING
- BUTTED TILES
- PRODUCTS RECOMMENDED FOR OUTDOOR USE
- GENERAL SALE TERMS
- USEFUL INFORMATION



- SOLS ANTIDÉRAPANTS
- PRODUITS RECTIFIÉS
- PRODUITS RECOMMANDÉS POUR L'EXTÉRIEUR
- CONDITIONS GENERALES DE VENTE
- INFORMATIONS UTILES



- RUTSCHFESTE BÖDEN
- MODIFIZIERTE PRODUKTE
- FÜR AUSSEN EMPFOHLENE PRODUKTE
- VERKAUFSBEDINGUNGEN
- WICHTIGE INFORMATION

### 2. PRODUCTOS RECTIFICADOS 🇪🇸

1. No mojar las piezas previamente a su colocación, pues pueden sufrir una ligera deformación que dificulte su colocación y su resultado final. Colocar en seco (sobre todo revestimiento).

2. Maestrear correctamente la pared antes de su colocación, pues cualquier rugosidad perjudica la colocación. El maestreo deberá hacerse con mortero y dejar fraguar, al menos, 48 horas.

3. Tras el fraguado, aplicar el cemento cola con llana dentada.

4. Pese a que el material rectificado se preste a una colocación sin junta, es aconsejable dejar una mínima distancia de 0,5 mm, con lo que evitaremos cualquier tipo de problema dimensional y eliminación de tensiones.

5. No golpear el material para colocarlo, pues cualquier mínimo desajuste en la pieza provocaría un efecto no deseado haciendo que las puntas no coincidieran.

6. Se deben completar las paredes.

7. No transitar sobre los pavimentos recién colocados que pudieran provocar problemas como los descritos en el punto 5.

8. Tener mucho cuidado en la manipulación de las piezas, ya que los bordes rectificados se prestan a una fácil rotura o despuntado por su canto vivo.

9. Rejuntar con una llana de goma una vez seco el material.

10. La limpieza del rejunte deberá hacerse antes del secado de este con una esponja húmeda.

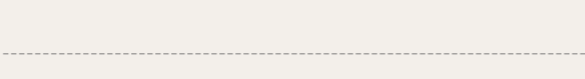

#### 3. PRODUCTOS RECOMENDADOS PARA EXTERIOR

1. En colocaciones exteriores, y más aún si las condiciones meteorológicas pueden llegar a ser extremas, se recomienda únicamente la colocación de productos pertenecientes al grupo BI (gres porcelánico) siendo el más aconsejado el grupo BIa por su absorción de agua inferior al 0,5 %.

2. Previamente a la colocación del material, se debe nivelar perfectamente la superficie con pasta niveladora o mortero, formando las pendientes necesarias (2 %) que impidan el estancamiento de agua, evitando así la formación de hielo con el correspondiente riesgo de rotura del material. Se recomienda, en terrazas o zonas descubiertas, la impermeabilización y drenaje conectado a sumidero por debajo del solado. Se recomienda el uso de juntas impermeables.

3. Utilizar el cemento cola correspondiente para material con baja absorción de agua y junta impermeable que impida el paso de agua por esta, impidiendo así el filtrado y evitando, como en el punto anterior, la rotura del material como consecuencia de la formación de hielo. Asimismo, la junta mínima de colocación de 1,5 mm sigue siendo la recomendada.

4. Hay que realizar juntas de dilatación en todo el perímetro cada 6-9 m2 y respetar las juntas de dilatación estructurales.

5. Debe utilizarse siempre una llana dentada en la aplicación del cemento cola y macizar mediante golpes con maza de goma. No deben quedar huecos bajo la superficie de la pieza, es decir, debe estar totalmente macizada.

6. En colocaciones de pavimentos en exterior, estos deben cumplir unos requisitos mínimos de antideslizamiento. Estos requerimientos son diferentes para cada país, habiendo vigentes distintos métodos de control del antideslizamiento como pudieran ser el Tortus, el péndulo o la rampa o plano inclinado.

7. No colocar en zonas permanentemente húmedas o susceptibles de tener presencia de humedad materiales que no cumplan con las especificaciones técnicas requeridas para este tipo de zonas.

### 2. BUTTED TILES 🇺🇸

1. Tiles should not be wetted prior to fitting as they can deform, which makes fitting difficult and affects the final result. Install dry. (Particularly with panels).

2. Skim the wall before tiling, as any roughness can affect the installation. Skim using mortar and leave to harden for at least 48 hours.

3. Once hardened, apply cement with a toothed trowel.

4. Although butted tiles might be described as joint-less, it is always advisable to leave a 0.5 mm gap to avoid problems resulting from dimensions and to relieve pressure.

5. Do not hammer the tiles into place as this could result in the tiles not being aligned correctly.

6. Walls should be tiled in their entirety.

7. Do not put pressure on freshly installed tiles as this can lead to problems as per note 5.

8. Be very careful while manipulating the tiles as their straight cut edges can break easily.

9. Grout with a rubber grouting float once set.

10. Excess grout must be cleaned off with a wet sponge before it dries.

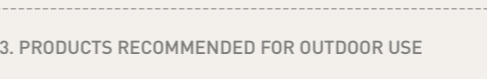
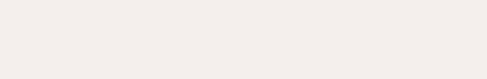

1. For exterior installations, and more so if weather conditions can be extreme, only group BI products (porcelain) are recommended, due to their low water absorption of 0.5%.

2. Before tiling, the surface should be levelled with levelling compound or mortar. There should also be 2% run-off to avoid ice forming which can damage the materials. Adequate drainage should be installed on terraces or open areas. Impermeable joints are recommended.

3. Cement should have low water absorption and impermeable grout should be used. This is to avoid water ingress which could result in ice damage. The minimum space recommended around the tiles is 1.5 mm.

4. There should be peripheral expansion joints for every 6-9 m2 and existing structural expansion joints should be respected.

5. A toothed trowel should always be used when applying cement. It must be compacted using a rubber hammer. The cement must be compacted such that no spaces remain behind tiles.

6. Exterior flooring must meet certain minimum anti-slip requirements. These requirements vary by country, employing various classification methods such as Tortus, pendulum or inclined ramp or plain.

7. For permanently wet areas or areas likely to be exposed to moisture, the correct materials that comply with all necessary technical specifications must be used.

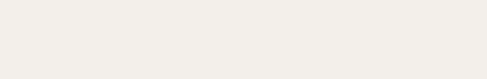
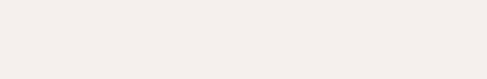

### 2. PRODUITS RECTIFIÉS 🇫🇷

1. Ne pas mouiller les carreaux avant de les poser car ceux-ci peuvent se déformer légèrement, ce qui complique la pose et nuit au résultat final. Poser à sec (notamment le revêtement mural).

2. Lisser correctement le mur avant la pose car toute rugosité pourrait compromettre la pose. Effectuer le lissage avec du mortier puis laisser durcir au moins 48 heures.

3. Après le durcissement, appliquer le mortier-colle à l'aide d'une taloche crantée.

4. Même si le matériau rectifié peut être posé sans joints, il est recommandé de laisser une distance minimale de 0,5 mm pour éviter tout type de problème dimensionnel et éliminer les tensions.

5. Ne pas tapoter sur le matériau pour le placer. En effet, un décalage minimal du carreau provoquerait un effet non souhaité, où les pointes ne coïncideraient pas.

6. Les murs doivent être complétés.

7. Ne pas circuler sur les revêtements de sol à peine posés susceptibles de provoquer des problèmes tels que ceux décrits au point 5.

8. Procéder avec le plus grand soin lors de la manipulation des carreaux rectifiés car ils sont fragiles ; leurs bords et arêtes vives se cassent très facilement.

9. Faire les joints avec une taloche en caoutchouc une fois que le matériau est sec.

10. Nettoyer les joints uniquement lorsqu'ils sont secs, à l'aide d'une éponge humide.

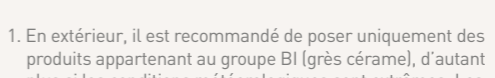

1. En extérieur, il est recommandé de poser uniquement des produits appartenant au groupe BI (grès cérame), d'autant plus si les conditions météorologiques sont extrêmes. Les produits du groupe BIa sont les plus adaptés en raison de leur absorption d'eau, inférieure à 0,5 %.

2. Avant la pose du matériau, il faut parfaitement niveler la surface avec un enduit de nivellement ou du mortier, en formant les pentes nécessaires (2 %) de façon à empêcher la stagnation de l'eau et à éviter la formation de gel, et donc le risque de rupture du matériau. Sur les terrasses et les zones sans toit, il est recommandé d'installer un système d'étanchéité et de drainage, relié à la canalisation sous le sol. Il est recommandé d'utiliser des joints imperméables.

3. Utiliser un mortier-colle adapté aux matériaux à faible absorption d'eau et aux joints imperméables pour éviter le passage de l'eau et les infiltrations qui pourraient entraîner, comme dans le point précédent, la rupture du matériau due à la formation de gel. Il est recommandé de respecter le même joint minimum de pose de 1,5 mm.

4. Il faut réaliser des joints de dilatation tout au long du périmètre tous les 6-9 m2, tout en respectant les joints de dilatation structurels.

5. Pour l'application du mortier-colle, toujours utiliser une taloche crantée et tasser en tapotant à l'aide d'un maillet en caoutchouc. Ne laisser aucun creux sous la surface du carrelage, qui doit être entièrement enfoncé.

6. Pour la pose en extérieur, les revêtements de sol doivent respecter des exigences minimales antidérapantes. Ces exigences sont différentes en fonction des pays ; il existe en effet plusieurs méthodes d'évaluation de la glissance, tels que Tortus, le pendule, ou encore la rampe ou plan incliné.

7. Dans les zones toujours humides ou susceptibles d'être humides, ne jamais poser des matériaux non conformes aux spécifications techniques exigées pour ce type de zone.

### 2. MODIFIZIERTE PRODUKTE 🇩🇪

1. Die Stücke vor der Verlegung nicht nass machen, da sie sich leicht verformen können, was die Verlegung erschwert und das Ergebnis beeinträchtigen kann. Trocken verlegen (besonders Verkleidungen).

2. Die Wand vor der Verlegung korrekt glätten, jede Rauheit beeinträchtigt die Verlegung. Die Glättung muss mit Mörtel vorgenommen werden und er mindestens 48 Stunden aushärten.

3. Nach der Aushärtung wird der Zementkleber mit einer gezahnten Kelle aufgetragen.

4. Obwohl das modifizierte Material ohne Fugen verlegt wird, empfehlen wir, einen Mindestabstand von 0,5 mm zu lassen, wodurch Ausdehnungsprobleme und Spannungen vermieden werden.

5. Klopfen Sie bei der Verlegung nicht auf das Material, da auch schon kleinste Verschiebungen einen nicht erwünschten Effekt mit sich bringen könnten und die Ecken nicht übereinstimmen.

6. Wände müssen vollständig verlegt werden.

7. Frisch verlegte Beläge nicht begehen, da die in Punkt 5 erläuterten Probleme auftreten könnten.

8. Die Stücke mit äußerster Sorgfalt handhaben, da die geschliffenen Ränder leicht brechen oder abstumpfen.

9. Sobald das Material trocken ist, mit einer Gummikelle verfugen.

10. Die Reinigung der Verfugung muss mit einem feuchten Schwamm vorgenommen werden, bevor das Material trocken ist.

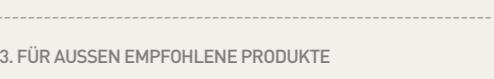

1. Bei Verlegungen in Außenbereichen, besonders bei extremen Klimabedingungen, empfehlen wir nur die Verlegung von Produkten der Gruppe BI (Feinsteinzeug), wobei die Gruppe BIa wegen ihrer Wasseraufnahme von weniger al 0,5 % empfohlen wird.

2. Vor der Verlegung des Materials muss die Oberfläche mit Nivellierungspaste oder Mörtel komplett plan gemacht werden, wobei die notwendigen Neigungen (2 %) geformt werden, die verhindern, dass sich Eis ansammelt, was verursachen könnte, dass das Material brechen könnte. Auf Terrassen und freie Bereiche empfiehlt sich eine Imprägnierung und Drainage mit Ablauf unter der Verlegung. Außerdem empfehlen wir wasserundurchlässige Fugen.

3. Es muss der für das Material mit geringer Wasseraufnahme geeignete Zement und eine wasserundurchlässige Fuge benutzt werden, damit nichts durchsickern kann, um zu verhindern, dass wie in dem vorigen Punkt, das Material durch Eisbildung bricht. Weiterhin wird eine Verlegung mit einem Abstand von 1,5 mm empfohlen.

4. Es müssen Dehnfugen auf der ganzen Fläche alle 6-9 m2 gesetzt werden, wobei strukturelle Dehnfugen berücksichtigt werden müssen.

5. Es muss immer eine gezahnte Kelle bei dem Umgang mit Zementkleber benutzt werden und einen Gummihammer, um die Stücke zurechtzuklopfen. Es dürfen keine Lücken unter der Oberfläche zurückbleiben, die Stücke müssen alle fest sitzen.

6. Bei der Verlegung in Außenbereichen müssen diese die Mindestanforderungen in Sachen Rutschfestigkeit erfüllen. Diese Anforderungen sind in jedem Land anders, wobei es verschiedene Kontrollmethoden zur Rutschfestigkeit gibt, wie etwa Tortus, das Pendel, Rampe oder die geneigte Fläche.

7. Nicht in permanent feuchten Bereichen oder die Feuchtigkeit vorweisen können verlegen und die nicht die erforderlichen technischen Spezifizierungen für diese Bereiche erfüllen.



## INFORMACIÓN EXTRA

### TECHNICAL INFORMATION

### INFORMATION TECHNIQUE

### TECHNISCHE INFORMATIONEN



#### 1. SUELOS ANTIDESLIZANTES

#### 2. PRODUCTOS RECTIFICADOS

#### 3. PRODUCTOS RECOMENDADOS PARA EXTERIOR

#### 4. CONDICIONES GENERALES DE VENTA

#### 5. INFORMACIÓN DE UTILIDAD



#### 1. ANTI-SLIP FLOORING

#### 2. BUTTED TILES

#### 3. PRODUCTS RECOMMENDED FOR OUTDOOR USE

#### 4. GENERAL SALE TERMS

#### 5. USEFUL INFORMATION



#### 1. SOLS ANTIDÉRAPANTS

#### 2. PRODUITS RECTIFIÉS

#### 3. PRODUITS RECOMMANDÉS POUR L'EXTÉRIEUR

#### 4. CONDITIONS GENERALES DE VENTE

#### 5. INFORMATIONS UTILES



#### 1. RUTSCHFESTE BÖDEN

#### 2. MODIFIZIERTE PRODUKTE

#### 3. FÜR AUSSEN EMPFOHLENE PRODUKTE

#### 4. VERKAUFSBEDINGUNGEN

#### 5. WICHTIGE INFORMATION

#### 4. CONDICIONES GENERALES DE VENTA

1. La mercancía viaja por cuenta y riesgo del comprador.

2. Los colores de catálogo e ilustraciones son puramente orientativas de la gama.

3. Nuestras materiales están sujetos a tonalidad y a las tolerancias que establece la norma ISO 13.006 / EN 14411.

4. No se responda de las reclamaciones sobre material ya colocado.

5. Nuestras garantías obedecen sólo a la reposición de material sin colocar.

6. Nos reservamos la facultad de cambiar nuestros precios con un preaviso de 30 días.

7. Los pagos se efectuarán directamente a Roig Ceramica SA (Rocersa), excepto en los casos en que deleguemos por escrito a personas autorizadas.

8. El retraso en 30 días a la fecha de cobro será sancionado como insolvencia. En tal caso será de nuestra facultad suspender los pedidos pendientes y por ello pedir judicialmente el pago de lo debido. Todos los gastos ocasionados por la demora, serán por cuenta del deudor.

9. Sobre la mercancía que ocupará cada factura, Roig Ceramica SA (Rocersa), se reserva el derecho de dominio hasta no haya sido cobrado el importe de la misma incluso sobre las transacciones a terceros.

10. En caso de litigio ambas partes se someterán a los Juzgados y Tribunales de Castellón (España).

**ENTREGA:** Todas las mercancías se consideran como recibidas y aceptadas en fábrica. Se expedirán por orden, cuenta y riesgo del comprador. Las faltas de peso o rotura deben reclamarse a las Compañías de Transportes, únicas responsables.

#### 5. INFORMACIÓN DE UTILIDAD

Todas las informaciones, datos y características técnicas que aparecen en este catálogo fueron acumulados hasta la edición de este (enero de 2018). El fabricante se reserva el derecho de introducir las modificaciones y cambios que considere necesarios en beneficio del producto y del cliente.

En caso de duda o confrontación de informaciones, estas deben ser confirmadas a través de la empresa o el agente que la represente, ya que los datos que aparecen en este catálogo no se considerarán vinculantes.

El contenido de este catálogo está protegido en su totalidad por copyright. Queda prohibida la reproducción total o parcial de las imágenes, textos, ilustraciones y conceptos gráficos sin la autorización expresa de Roig Cerámica, S.A.

Debido a los procesos técnicos de reproducción, los colores son aproximados, no exactos.

#### 4. GENERAL SALE TERMS

The merchandise is sent at buyer's risk and account

The colour and images of the series shown in the catalogue are purely orientative

Our products are subject to shade and caliber variation, as well as tolerances as per the european norm in force ISO 13.006 / EN 14411.

We will not be held responsible for any items once these have been laid out

Our guarantee applies only for tiles that are not installed

We reserve the rights to change prices with a previous 30 day notice.

Payment are strictly made to Roig Ceramica SA (Rocersa), except in those cases when we delegate in writing to be effected to an authorized person.

Any overdue payments for 30 days will be considered as insolvency, and in such a situation we reserve the rights to put any pending orders on hold, and take legal action if considered convenient, and all expenses incurred will be at debtor's account.

The goods listed on every invoice remain property of Roig Ceramica SA (Rocersa), until these have been cleared in full, this applies to any transactions made with agents or third parties too

In case of litigation this will be submitted trough the court of justice in Castellon.

**DELIVERY:** All the goods will be considered as accepted & received by the customer once these leave the factory, and these will be sent by order of the customer and at his own account and risk any breakage or missing items are to be claimed to the transport company

Carriers are responsible for breakage and / or underweight / overweight

#### 5. USEFUL INFORMATION

All information, data and technical characteristics appearing in this catalogue, were gathered prior to the publication of same (january 2018). The manufacturer reserves the right to make changes considered necessary for the benefit of the product and of the client.

In case of doubt or contradictions, these must be taken up with the company or its agent as data contained herein shall not be binding.

The entire content of this catalogue is protected by copyright. Reproduction in whole or in part of any images, text, illustrations or graphical concepts is prohibited without express authorisation of Roig Cerámica, S.A.

Owing to printing processes, colours shown are approximate.

#### 4. CONDITIONS GENERALES DE VENTE

1. La marchandise voyage aux risques et périls de l'acheteur.

2. Les coloris de nos catalogues et illustrations sont uniquement une orientation de notre gamme.

3. Nos produits s'adaptent aux tolérances données par les normes ISO 13.006 / EN 14411 établies.

4. Nous ne pouvons accepter de réclamation de nos produits après sa pose, s'il existe un problème de qualité apparent.

5. Nos garanties ne sont valables, en cas de défaut, que pour les produits non posés.

6. Nous nous réservons le droit de modifier nos prix et tarifs avec un préavis de 30 jours.

7. Les paiements s'effectueront directement à Roig Ceramica SA (Rocersa), sauf quand la Société donne l'autorisation par écrit à une autre personne.

8. Un retard de règlement supérieur à 30 jours à la date accordée sera considéré comme manque de solvabilité de la part du client, sauf preuve du contraire. Les commandes en cours seraient paralysées ou annulées. Le règlement pouvant être réclamé par VOIE JUDICIAIRE, tenants comptes des frais d'agios et autres.

9. Roig Ceramica SA (Rocersa), se réserve le droit de propriété, selon la LOI NUM 80.325 du 2 mai 1980, jusqu'à complet paiement de pouvoir faire des poursuites aux tierces personnes.

10. En cas de litige, seul le Tribunal de Castellon (Espagne) est compétent.

La marchandise est vendue au DEPART USINE d'où elle est chargée dans de bonnes conditions, celle-ci ne pourra faire l'objet de réclamations dans le cas de casse ou autres causes similaires qu'au TRANSPORTEUR correspondant.

#### 5. INFORMATIONS UTILES

L'ensemble des informations, des données et des caractéristiques techniques que contient ce catalogue ont été accumulées jusqu'à sa publication (janvier 2018). Le fabricant se réserve le droit de réaliser les modifications et les changements qu'il juge nécessaires pour améliorer le produit et la satisfaction du client.

En cas de doute ou de confrontations d'informations, celles-ci sont à confirmer auprès de l'entreprise ou de l'agent qui la représente, car celles qui figurent dans ce catalogue ne sont pas considérées comme contraignantes.

Le contenu de ce catalogue est protégé dans sa totalité par copyright. Toute reproduction des images, textes, illustrations et concepts graphiques, même partielle, est interdite dans l'autorisation expresse de Roig Cerámica, S.A.

En raison des procédés techniques de reproduction, les couleurs ne sont pas précises mais approximatives.

#### 4. VERKAUFSBEDINGUNGEN

1. Die Ware wird auf eigene Gefahr des Käufers verfrachtet.

2. Die Farben in unsere Prospekten und Kataloge dienen nur zur Orientierung.

3. Unser Material entspricht in Brand und Toleranz der aktuellen Norm (ISO 13.006 / EN 14411)

4. Reklamationen nach Verlegen des Materials werden nicht akzeptiert.

5. Unseren Garantien und somit Ersatzlieferungen sind nur gültig, wenn das Material noch nicht verlegt wurde.

6. Wir behalten uns das Recht vor, unsere Preise mit einem Voravis von 30 Tagen zu ändern.

7. Die Rechnungen werden direkt an Roig Ceramica SA (Rocersa), bezahlt, außer wenn wir schriftlich eine bestimmte Person damit beauftragen.

8. Eine Verspätung der Zahlung in mehr als 30 Tagen, wird als Zahlungsunfähigkeit von Seitens des Kunden betrachtet. In diesem Fall werden laufenden Bestellungen storniert und der Gesamtbetrag gesetzlich eingetrieben. Jeglich verursachte Kosten sind vom Schuldner zu tragen.

9. Bis zur vollständigen Bezahlung der Rechnung reserviert sich Roig Ceramica SA (Rocersa), das vollständige Eigentumsrecht vor. Dies beinhaltet auch Verhandlungen mit Dritten Personen.

10. Im Streitfall ist für beide Parteien der Gerichtshof in Castellon (Spanien) zuständig.

**ANLIEFERUNG:** Die Ware wird im Werk übernommen und auf Risiko des Käufers verfrachtet. Fehlende Gewichte oder Schäden des Materials müssen direkt an den Spediteur reklamiert werden, da diese die einzigen Verantwortlichen sind.

#### 5. WICHTIGE INFORMATION

Alle Informationen, Daten und technische Eigenschaften in diesem Katalog wurden während der Auflage (Januar 2018) gesammelt. Der Hersteller hält sich das Recht vor, die notwendigen Veränderungen und Modifizierungen zu Gunsten des Produkts und des Kunden vorzunehmen.

Bei Fragen oder gegensätzlichen Informationen müssen diese von dem Unternehmen oder dem Vertreter bestätigt werden, da die Daten in dem Katalog ohne Gewähr sind.

Der Inhalt des Katalogs ist vollständig durch Copyright geschützt. Eine vollständige oder partielle Wiedergabe der Bilder, Texte, Abbildungen und graphischen Konzepten ist ohne die ausdrückliche Genehmigung von Roig Cerámica, S.A. untersagt.

Durch die technischen Wiedergabeprozesse sind die Farben ungefähr, nicht exakt.



# LISTADO DE REFERENCIAS

## REFERENCES

## LISTE DES RÉFÉRENCES

## LISTE DER REFERENZEN

### A

●●●	ARUBA 20 PEARL RC	60x60cm	185
●●●	ARUBA 20 PEARL RC	50x100cm	185
●●●	ARUBA 20 PEARL RC	100x100cm	185
●●●	ARUBA 20 GREY RC	60x60cm	185
●●●	ARUBA 20 GREY RC	50x100cm	185
●●●	ARUBA 20 GREY RC	100x100cm	185
●●●	ARUBA 20 GRAPHITE RC	60x60cm	187
●●●	ARUBA 20 GRAPHITE RC	50x100cm	187
●●●	ARUBA 20 GRAPHITE RC	100x100cm	187
●●●	ARUBA 20 TAUPE RC	60x60cm	187
●●●	ARUBA 20 TAUPE RC	50x100cm	187
●●●	ARUBA 20 TAUPE RC	100x100cm	187
●●	ATMOSPHERE 20 LIGHT-DARK ANT RC	60x60cm	113
●●	ATMOSPHERE 20 LIGHT-DARK ANT	61x61cm	113
●●	ATMOSPHERE 20 LIGHT-DARK ANT RC	60x120cm	113
●●	ATMOSPHERE 20 SMOKE-DARK ANT RC	60x60cm	113
●●	ATMOSPHERE 20 SMOKE-DARK ANT	61x61cm	113
●●	ATMOSPHERE 20 SMOKE-DARK ANT RC	60x120cm	113
●●	ATMOSPHERE 20 ANTHRACITE-DARK ANT RC	60x60cm	113
●●	ATMOSPHERE 20 ANTHRACITE-DARK ANT	61x61cm	113
●●	ATMOSPHERE 20 ANTHRACITE-DARK ANT RC	60x120cm	113
●●	ATMOSPHERE 20 MINK-DARK ANT RC	60x60cm	115
●●	ATMOSPHERE 20 MINK-DARK ANT	61x61cm	115
●●	ATMOSPHERE 20 MINK-DARK ANT RC	60x120cm	115
●●	ATMOSPHERE 20 TAUPE-DARK ANT RC	60x60cm	115
●●	ATMOSPHERE 20 TAUPE-DARK ANT	61x61cm	115
●●	ATMOSPHERE 20 TAUPE-DARK ANT RC	60x120cm	115
●●	AXIS 20 WHITE ANT RC	60x60cm	192
●●	AXIS 20 WHITE ANT	61x61cm	192
●●	AXIS 20 WHITE ANT RC	60x120cm	192
●●	AXIS 20 GREY ANT RC	60x60cm	193
●●	AXIS 20 GREY ANT	61x61cm	193
●●	AXIS 20 GREY ANT RC	60x120cm	193
●●	AXIS 20 BLACK ANT RC	60x60cm	194
●●	AXIS 20 BLACK ANT	61x61cm	194
●●	AXIS 20 BLACK ANT RC	60x120cm	194
●●	AXIS 20 CREAM ANT RC	60x60cm	195
●●	AXIS 20 CREAM ANT	61x61cm	195
●●	AXIS 20 CREAM ANT RC	60x120cm	195

● OUTDOOR 20  
● DDS  
● PORCELAIN TILES

### B

●●	BELFORT 20 GRIS ANT RC	60x60cm	121
●●	BELFORT 20 GRIS ANT	61x61cm	121
●●	BELFORT 20 GRIS ANT RC	75x75cm	121
●●	BELFORT 20 GRAFITO ANT RC	60x60cm	121
●●	BELFORT 20 GRAFITO ANT	61x61cm	121
●●	BELFORT 20 GRAFITO ANT RC	75x75cm	121
●●	BLACKSHEEP 20 LIGHT ANT RC	75x75cm	200
●●	BLACKSHEEP 20 LIGHT ANT RC	60x120cm	200
●●	BLACKSHEEP 20 DARK ANT RC	75x75cm	201
●●	BLACKSHEEP 20 DARK ANT RC	60x120cm	201
●●	BLUENORTE 20 GRIS ANT RC	60x60cm	206
●●	BLUENORTE 20 GRIS ANT	61x61cm	206
●●	BLUENORTE 20 GRIS ANT RC	75x75cm	206
●●	BLUENORTE 20 GRIS ANT RC	60x120cm	206
●●	BLUENORTE 20 NEGRO ANT RC	60x60cm	207
●●	BLUENORTE 20 NEGRO ANT	61x61cm	207
●●	BLUENORTE 20 NEGRO RC	75x75cm	207
●●	BLUENORTE 20 NEGRO ANT RC	60x120cm	207
●●	BRUGES 20 PEARL	20x20cm	208
●●	BRUGES 20 GREY	20x20cm	214

### C

●●	CHRONO 20 WHITE ANT RC	60x60cm	220
●●	CHRONO 20 WHITE ANT	61x61cm	220
●●	CHRONO 20 WHITE ANT RC	60x120cm	220
●●	CHRONO 20 GREY ANT RC	60x60cm	221
●●	CHRONO 20 GREY ANT	61x61cm	221
●●	CHRONO 20 GREY ANT RC	60x120cm	221
●●	CHRONO 20 CREAM ANT RC	60x60cm	223
●●	CHRONO 20 CREAM ANT	61x61cm	223
●●	CHRONO 20 CREAM ANT RC	60x120cm	223
●●	CITADEL 20 SMOKE ANT RC	75x75cm	228
●●	CITADEL 20 SMOKE ANT RC	60x120cm	228
●●	CITADEL 20 GREY ANT RC	75x75cm	229
●●	CITADEL 20 GREY ANT RC	60x120cm	229
●●	CITADEL 20 BLACK ANT RC	75x75cm	231
●●	CITADEL 20 BLACK ANT RC	60x120cm	231
●●	CONTRACT 20 WHITE ANT RC	60x120cm	126
●●	CONTRACT 20 GRAFITO ANT RC	60x120cm	127
●●	CONTRACT 20 GREY ANT RC	60x120cm	129

### D

●●	DOVER 20 WHITE ANT RC	60x60cm	236
●●	DOVER 20 WHITE ANT	61x61cm	236
●●	DOVER 20 WHITE ANT RC	75x75cm	236

●●	DOVER 20 WHITE ANT RC	60x120cm	236
●●	DOVER 20 SMOKE ANT RC	60x60cm	237
●●	DOVER 20 SMOKE ANT	61x61cm	237
●●	DOVER 20 SMOKE ANT RC	75x75cm	237
●●	DOVER 20 SMOKE ANT RC	60x120cm	237
●●	DOVER 20 GREY ANT RC	60x60cm	238
●●	DOVER 20 GREY ANT	61x61cm	238
●●	DOVER 20 GREY ANT RC	75x75cm	238
●●	DOVER 20 GREY ANT RC	60x120cm	238
●●	DOVER 20 CREAM ANT RC	60x60cm	239
●●	DOVER 20 CREAM ANT	61x61cm	239
●●	DOVER 20 CREAM ANT RC	75x75cm	239
●●	DOVER 20 CREAM ANT RC	60x120cm	239

### E

●●	ETERNAL STONE 20 GREY RC	60x60cm	135
●●	ETERNAL STONE 20 GRAPHITE RC	60x60cm	135
●●	ETERNAL STONE 20 DARK RC	60x60cm	135
●●	ETERNAL STONE 20 GREY RC	100x100cm	135
●●	ETERNAL STONE 20 GRAPHITE RC	100x100cm	135
●●	ETERNAL STONE 20 DARK RC	100x100cm	135
●●	ETERNAL STONE 20 GREY RC	20x20cm	140
●●	ETERNAL STONE 20 GRAPHITE RC	20x20cm	141
●●	ETERNAL STONE 20 DARK RC	20x20cm	142
●●	EVERGLOW 20 DARK ANT RC	29,5x120cm	79
●●	EVERGLOW 20 WHITE ANT RC	29,5x120cm	79
●●	EVERGLOW 20 GREY ANT RC	29,5x120cm	79
●●	EVERGLOW 20 NATURE ANT RC	29,5x120cm	81
●●	EVERGLOW 20 ASH ANT RC	29,5x120cm	81

### F

●●	FLOW 20 WHITE ANT RC	29,5x120cm	87
●●	FLOW 20 LIGHT ANT RC	29,5x120cm	87
●●	FLOW 20 SMOKE ANT RC	29,5x120cm	87
●●	FLOW 20 MINK ANT RC	29,5x120cm	89
●●	FLOW 20 NATURE ANT RC	29,5x120cm	89

### I

●●	ICON 20 GREY ANT RC	29,5x120cm	95
●●	ICON 20 NATURE ANT RC	29,5x120cm	95

### L

●●	LIVERMORE 20 CALCITA ANT RC	60x60cm	245
●●	LIVERMORE 20 CALCITA ANT	61x61cm	245

●●	LIVERMORE 20 CALCITA ANT RC	60x120cm	245
●●	LIVERMORE 20 VISON ANT RC	60x60cm	247
●●	LIVERMORE 20 VISON ANT	61x61cm	247
●●	LIVERMORE 20 VISON ANT RC	60x120cm	247
●●	LIVERMORE 20 BLACK ANT RC	60x60cm	248
●●	LIVERMORE 20 BLACK ANT	61x61cm	248
●●	LIVERMORE 20 BLACK ANT RC	60x120cm	248
●●	LIVERMORE 20 PEARL ANT RC	60x60cm	249
●●	LIVERMORE 20 PEARL ANT	61x61cm	249
●●	LIVERMORE 20 PEARL ANT RC	60x120cm	249
●●	LIVERMORE 20 GREY ANT RC	60x60cm	251
●●	LIVERMORE 20 GREY ANT	61x61cm	251
●●	LIVERMORE 20 GREY ANT RC	60x120cm	251

### M

●●	MAKE UP 20 WHITE RC	60x120cm	146
●●	MAKE UP 20 WHITE RC	100x100cm	146
●●	MAKE UP 20 GREY RC	60x120cm	147
●●	MAKE UP 20 GREY RC	100x100cm	147
●●	MAKE UP 20 DARK RC	60x120cm	148
●●	MAKE UP 20 DARK RC	100x100cm	148
●●	MAKE UP 20 MINK RC	60x120cm	149
●●	MAKE UP 20 MINK RC	100x100cm	149
●●	MAKE UP HIDRA OUT 20 COLD RC	60x60cm	150
●●	MAKE UP HIDRA OUT 20 WARM RC	60x60cm	150
●●	MAKE UP 20 WHITE RC	20x20cm	156
●●	MAKE UP 20 GREY RC	20x20cm	157
●●	MAKE UP 20 DARK RC	20x20cm	158
●●	MAKE UP 20 MINK RC	20x20cm	159
●●	MAKE UP HIDRA 20 COLD RC	20x20cm	162
●●	MAKE UP HIDRA 20 WARM RC	20x20cm	163
●●	MATERIA 20 MARFIL ANT RC	60x60cm	257
●●	MATERIA 20 MARFIL ANT	61x61cm	257
●●	MATERIA 20 MARFIL ANT RC	75x75cm	257
●●	MATERIA 20 BEIGE ANT RC	60x60cm	257
●●	MATERIA 20 BEIGE ANT	61x61cm	257
●●	MATERIA 20 BLANCO ANT RC	60x60cm	259
●●	MATERIA 20 BLANCO ANT	61x61cm	259
●●	MATERIA 20 GRIS ANT RC	60x60cm	259
●●	MATERIA 20 GRIS ANT	61x61cm	259
●●	MATERIA 20 GRIS ANT RC	75x75cm	259
●●	MATERIA 20 ANTRACITA ANT RC	60x60cm	259
●●	MATERIA 20 ANTRACITA ANT	61x61cm	259
●●	MATERIA 20 ANTRACITA ANT RC	75x75cm	259
●●	MOON 20 GREY RC	60x60cm	265
●●	MOON 20 GREY RC	100x100cm	265

●●	MOON 20 DARK RC	60x60cm	265
●●	MOON 20 DARK RC	100x100cm	265
●●	MUSTANG 20 MINK ANT RC	60x60cm	169
●●	MUSTANG 20 MINK ANT	61x61cm	169
●●	MUSTANG 20 MINK ANT RC	75x75cm	169
●●	MUSTANG 20 NOCE ANT RC	60x60cm	169
●●	MUSTANG 20 NOCE ANT	61x61cm	169
●●	MUSTANG 20 NOCE ANT RC	75x75cm	169
●●	MUSTANG 20 WHITE ANT RC	60x60cm	171
●●	MUSTANG 20 WHITE ANT	61x61cm	171
●●	MUSTANG 20 WHITE ANT RC	75x75cm	171
●●	MUSTANG 20 GREY ANT RC	60x60cm	171
●●	MUSTANG 20 GREY ANT	61x61cm	171
●●	MUSTANG 20 GREY ANT RC	75x75cm	171
●●	MUSTANG 20 ANTHRACITE ANT RC	60x60cm	171
●●	MUSTANG 20 ANTHRACITE ANT	61x61cm	171
●●	MUSTANG 20 ANTHRACITE ANT RC	75x75cm	171

### O

●●	OLD STATION 20 WHITE ANT RC	29,5x120cm	100
●●	OLD STATION 20 MIX SMOKE ANT RC	29,5x120cm	100
●●	OLD STATION 20 MIX NATURE ANT RC	29,5x120cm	101

### S

●●	SYNERGY 20 SAND ANT RC	60x60cm	177
●●	SYNERGY 20 SAND ANT	61x61cm	177
●●	SYNERGY 20 BROWN ANT RC	60x60cm	177
●●	SYNERGY 20 BROWN ANT	61x61cm	177
●●	SYNERGY 20 PEARL ANT RC	60x60cm	178
●●	SYNERGY 20 PEARL ANT	61x61cm	178
●●	SYNERGY 20 GREY ANT RC	60x60cm	178
●●	SYNERGY 20 GREY ANT	61x61cm	178
●●	SYNERGY 20 BLACK ANT RC	60x60cm	178
●●	SYNERGY 20 BLACK ANT	61x61cm	178

### V

●●	VENICE 20 NATURE ANT RC	60x60cm	106
●●	VENICE 20 PEARL ANT RC	60x60cm	106
●●	VENICE 20 GRAFITO ANT RC	60x60cm	106
●●	VENICE 20 NATURE ANT	61x61cm	106
●●	VENICE 20 PEARL ANT	61x61cm	106
●●	VENICE 20 GRAFITO ANT	61x61cm	106



rocersa®



**rocersa®**

**Roig Cerámica S.A.**

Camino viejo de Onda, S/N. 12540 Vila-real (Castellón)

T. 964 50 62 42 • F. 964 53 14 28

rocersa@rocersa.es • www.rocersa.es